



The Sound Choice  
for Leak Detection.™

## User Guide: Sentinel 2 (2-point Pressure control system)



**Warning:** This manual contains important safety and operating information.  
Please read, understand, and follow the instructions in the manual.

MAN-163-0004-B

September 2022

## TABLE OF CONTENTS

1	System Documentation and Support of Product .....	5
1.1	Documentation and Technical support .....	5
1.2	Safety .....	5
2	Overview .....	6
2.1	Introduction .....	6
2.2	Server integration option: DataGate and PressView Websites .....	9
2.3	Communicating with Sentinel 2 .....	10
2.3.1	Download of IDT (PC version) .....	10
2.3.2	Connecting the Comms Cable .....	10
2.3.3	Loading Sentinel 2 settings into IDT .....	11
2.3.4	Saving settings from IDT into Sentinel 2 .....	13
2.4	Sentinel 2 System Kits .....	15
2.5	Sentinel 2 Control Box – Description .....	15
2.5.1	Logger functions .....	15
2.5.2	PRV Control functions .....	16
2.5.3	Controller Description .....	16
2.6	Hydroswitch - Description .....	18
2.7	Mechanical Actuator .....	21
2.8	Summary of PRV Function (Pilot operated) .....	21
2.8.1	Main valve .....	21
2.8.2	Pilot Valve operation .....	22
2.8.3	Pilot operated pressure reducing valve .....	22
2.9	PRV Function (under Sentinel 2 control) .....	23
2.9.1	Sentinel 2 Mechanical Actuator .....	23
2.9.2	Theory of operation (2-point pressure modulation; High and Low) .....	24
3	Configuration options (diagrams) .....	26
3.1	Key to components within the diagrams .....	26
3.2	Standard installations: 2-point pressure control .....	29
3.2.1	Using: internal transducers (Upstream pressure < 90 m) .....	29
3.2.2	Using: external pressure transducers (Upstream pressure < 90 m) .....	30
3.2.3	Using: internal transducers (Upstream pressure > 90 m) .....	31
3.2.4	Using: external pressure transducers (Upstream pressure > 90 m) .....	32
3.3	(Other Installation Options) .....	33

3.3.1	Additional Data Logging interfaces .....	33
4	Installation procedure .....	34
4.1	Position Control box and Hydroswitch / Connect .....	35
4.1.1	Antenna .....	35
4.1.2	Battery .....	35
4.1.3	Hydroswitch .....	35
4.2	Connection to the Flow meter .....	36
4.3	Connect External Pressure transducers to Sentinel 2 .....	36
4.4	Check / modify Sentinel 2 channel settings.....	37
4.5	Re-zero Pressure transducers .....	43
4.6	Prepare the pipework for the Sentinel 2.....	45
4.7	Prepare the PRV for Sentinel water feed / pressure transducers .....	46
4.8	Connect Sentinel side pipework .....	47
4.9	Set Hydroswitch valve into Auto mode.....	48
4.10	Connect transducers and control pipework on PRV side.....	49
4.11	Preparing to fit the actuator.....	49
4.12	Fitting and adjusting the HWM mechanical actuator .....	51
4.13	Bleed air from the pipework and actuator.....	53
4.14	Test Pressure transducers .....	54
4.15	Testing the Actuator and PRV Pressure change response.....	55
4.16	PRV Control method and Settings .....	56
4.16.1	Setup of pressure control using a Time profile .....	56
4.16.2	Setup of a (pressure) Safety Override for Time Control .....	58
4.16.3	Setup of pressure control using a Flow profile.....	58
4.16.4	Setup of pressure control using a combined Time and Flow profile.....	61
4.17	Setup for annual time adjustments .....	61
4.18	Save Program / Activating Sentinel PRV control.....	62
4.19	Setting Logger Startup / Measurement Sample Rates .....	63
4.20	Setup of Data Delivery .....	63
4.20.1	Call-in times (schedule and protocol).....	63
4.20.2	Destination.....	64
4.20.3	Setting Network access parameters.....	65
4.21	Communications / Antenna location check.....	66
4.22	Verification of the configuration .....	68
4.23	Protection from Frost.....	68

5	Graphing / data download and preview.....	69
5.1	Manual download of data into IDT / Preview as a graph .....	69
6	Connection Information .....	71
6.1.1	FLOW Meter connection / cable RAG 93 .....	71
7	Maintenance, Service and Repair .....	72
7.1.1	Return of product for Investigation, Service. Or Repair .....	72
7.1.2	Putting the equipment into Shipping Mode .....	73
8	Appendix A - IDT Options.....	75
8.1	Change of units of measure for displayed data.....	75

---

# 1 SYSTEM DOCUMENTATION AND SUPPORT OF PRODUCT

---

## 1.1 DOCUMENTATION AND TECHNICAL SUPPORT

Thank you for choosing a HWM device. We trust it will provide you with many years of service.

The Sentinel 2 system is designed to control the outlet pressure from a clean-water pressure reducing valve.

This user-guide provides details of the Sentinel 2 system components. It provides details of how to install the product in a stand-alone mode and also (optional) integration with the HWM DataGate system, providing on-line viewing of pressure measurements.

This user-guide covers the following models:

<u>Model Number(s)</u>	<u>Description</u>
C163C/**/**/S*	Sentinel 2 Controller unit
C163F/**/**/S*	A kit including the Sentinel 2 Control box plus additional components to make a complete Sentinel 2 system.

<u>Accessories</u>	<u>Description</u>
RCA7922L	Hydroswitch with solenoid.

Note: The part-number structure is similar to the Pegasus 2 family of models. Pegasus 2 has its own user-guide.

Note: The system periodically has new features and changes released, thus you may observe slight changes in layout from those shown in this manual. Additionally, views can vary depending on what user-role you have been given and its permissions.

HWM provides support of the Sentinel 2 system by means of our customer support webpages: (Note: Customer registration is required to access).

<https://www.hwmglobal.com/help-and-downloads/>

Should you have any questions that are not covered by this manual or the system's online help, please contact the HWM Technical Support team on +44 (0) 1633 489479, or email [cservice@hwm-water.com](mailto:cservice@hwm-water.com)

## 1.2 SAFETY

Before continuing, please read the "Safety Warnings and Approvals Information" document supplied with the product.

**WARNING:** This equipment should be installed, adjusted, and serviced by qualified water industry maintenance personnel familiar with the construction and operation of the equipment and the hazards involved. Failure to observe this precaution could result in damage to the water network.

## 2 OVERVIEW

---

### 2.1 INTRODUCTION

Sentinel 2 is a system that is used to control the outlet pressure of a pressure reducing valve (PRV) within a clean-water supply pipe network. This section gives an overview of Sentinel 2, the equipment that is required to use it, and other (optional) system elements.

The system is designed to control pressure reducing valves that are designed and manufactured by 3<sup>rd</sup> party suppliers. Only general details of PRV valve construction are included in this manual, and any images are for illustration purposes only.

Pressure control can be:

- 2-point control:  
i.e. Automatic switching between two pre-set pressure levels (High and Low).  
The Sentinel 2 product is ideal for this situation.
- Continuous control:  
i.e. Incremental adjustment of pressure, between a maximum and minimum;  
The Pegasus 2 product is ideal for this situation.  
(Refer to the Pegasus 2 manual for further details)

Sentinel 2 switches the PRV output pressure to either a High or Low setting based on a pre-determined pressure profile.

The profile can be based on:

- The time of day, or
- The flow rate (demand) of water, or
- Both of the above.

The pressure profiles are defined by settings or tables within the unit. Tables can be entered manually during installation. Sentinel 2 can also communicate with a central server that stores its measurement data. The server can be used for remotely analysing the effectiveness of the pressure control and (if required) remotely update the unit's settings. (This is achieved via PressView web software).

The system also offers a fail-safe mode, where it can operate the PRV at a fixed outlet pressure when certain fault conditions occur (e.g. detection of a sensor failure).

Sentinel 2 includes a built-in data logger.

The Sentinel 2 system typically consists of the following parts:

- A Control Box unit.
- A Hydroswitch unit.
- A HWM mechanical actuator.
- An accessory kit for plumbing-in the Sentinel 2 system to work with the PRV. (HWM can supply standard kits containing colored plastic tubing, a 3-way manual valve, quick-connect fittings).
- Hanging bracket.

- Cables for sensors (transducers or meters).
- An antenna for communication of data over the mobile cellular network (For server integration).
- External battery (optional / if required).
- A USB Communications cable (an accessory required for on-site installation, programming, and data retrieval).

The system will contain interfaces for measurement of water pressure. These may be built-in transducers (for connection to the system via water pipes) or (where external transducers are employed) attached via cables.

The system operates from internal batteries or (optional) using an additional external HWM battery unit (see opposite).

Where supplied, the external battery power is used to extend the battery life of the system or more frequent communications with the host server.

The battery connection has to be removed whenever the communications cable is fitted; they share the same connector. Be sure to re-connect the battery prior to leaving the unit.



---

### **Sentinel 2 compatibility with Sentinel Plus**

The Sentinel 2 system replaces previous generations of HWM pressure control systems, known as Sentinel Plus.

Existing sensors and pipework may be compatible and may be re-used with a Sentinel 2 installation if in good condition; Discuss with your HWM sales representative if required.

The USB Communications cable is compatible between Sentinel Plus and Sentinel 2 systems.

---

The Sentinel 2 system controls the PRV by means of hydraulic actuation. It can monitor upstream pressure, downstream pressure, and flow through the PRV. It may therefore require connection to various points in the water supply and PRV.

An example of a PRV with Sentinel 2 system installed is shown opposite.

Several plumbing configurations exist, depending on upstream and downstream pressures. Configuration also depends on the parameters that need to be logged.

The model number of each unit must be selected to match the requirements of the installation.

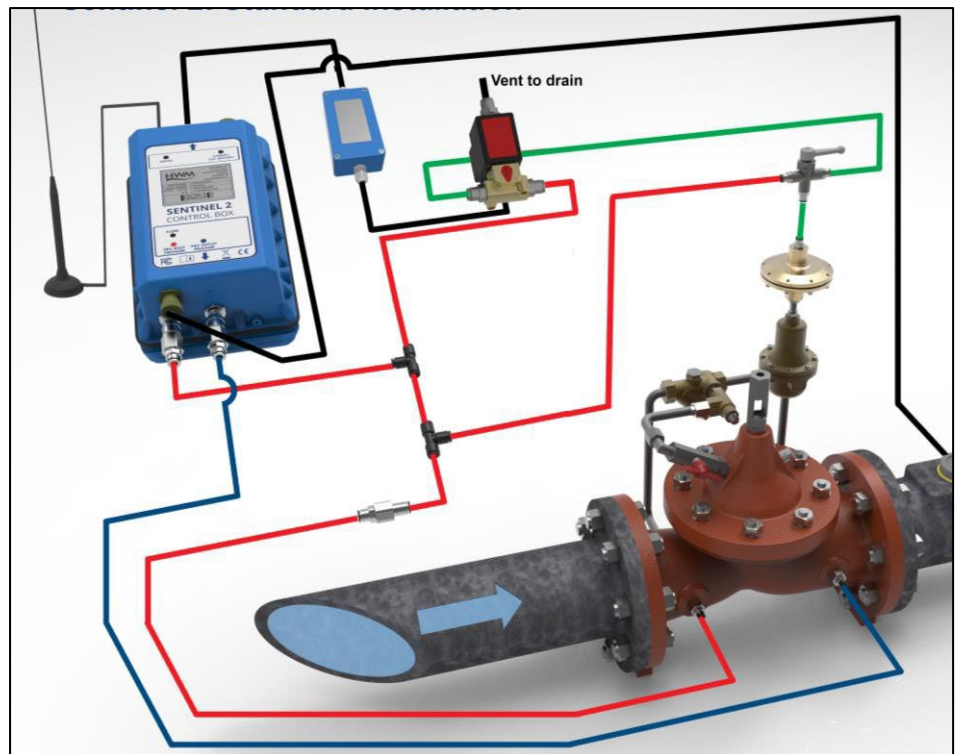

An example of the standard installation accessory kit, plus the actuator, and brackets are shown above and opposite.





## 2.2 SERVER INTEGRATION OPTION: DATAGATE AND PRESSVIEW WEBSITES

When integrated with HWM's DataGate server, the Sentinel measurement data can be stored on the server every time the unit makes a call-in.

The data can be viewed remotely / graphically by anyone with a suitable user account (and password) using a standard web-browser. The data is viewed in PressView.

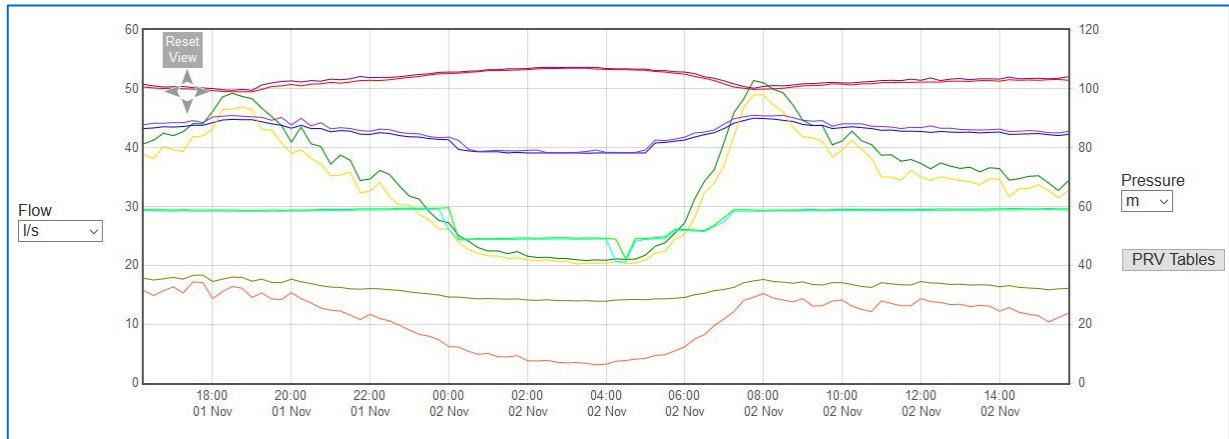

The PressView website allows the Sentinel 2 data to be combined with pressure measurements made (by another HWM logger device) some distance down-stream of the PRV (e.g. at a “critical point”). Both the local and remote measurements can be assessed by a user, and (whenever an adjustment is needed) revised pressure profiles can be sent to the Sentinel unit. This feature is not covered further in this document; refer to the User-Guide or instructions for PressView for more details.

The Sentinel 2 can also send any fault notifications (alarms) to the server for forwarding to interested parties.

## 2.3 COMMUNICATING WITH SENTINEL 2

To communicate with the Sentinel 2 system a communications cable is required (part-number COMAEUSB or CABA2075) to connect the Control Box to a PC.

The PC also requires a HWM software utility called “Installation and Diagnostic Tool”, or more commonly known as IDT (PC version).

IDT is introduced in this section but relevant parts of it will also appear at places elsewhere in the manual.

### 2.3.1 Download of IDT (PC version)

IDT (PC version) can be downloaded from the HWM Customer Support website, or from the following webpage: <https://www.hwmglobal.com/idt-support/>

Note: The user has to be registered by HWM and have a password to gain access).

Once installed, an icon will be available on the PC desktop similar to that shown opposite:



Launching the program will result in IDT loading and an initial screen, as shown.

To read the Sentinel 2 device a suitable Comms cable must first be fitted.



### 2.3.2 Connecting the Comms Cable

A cable of the type COMAE/USB is shown opposite.

Attach the Comms cable to the “COMMS / EXT.BATTERY” connector of the Sentinel 2 Control Box.

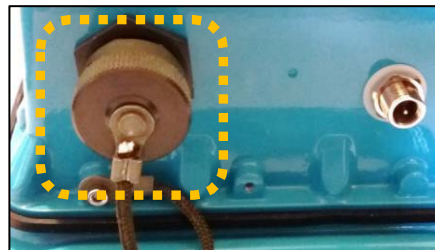

Connect the other side of the connector to the PC (USB port).



It is now possible to communicate with the Sentinel 2 system using IDT.

### 2.3.3 Loading Sentinel 2 settings into IDT

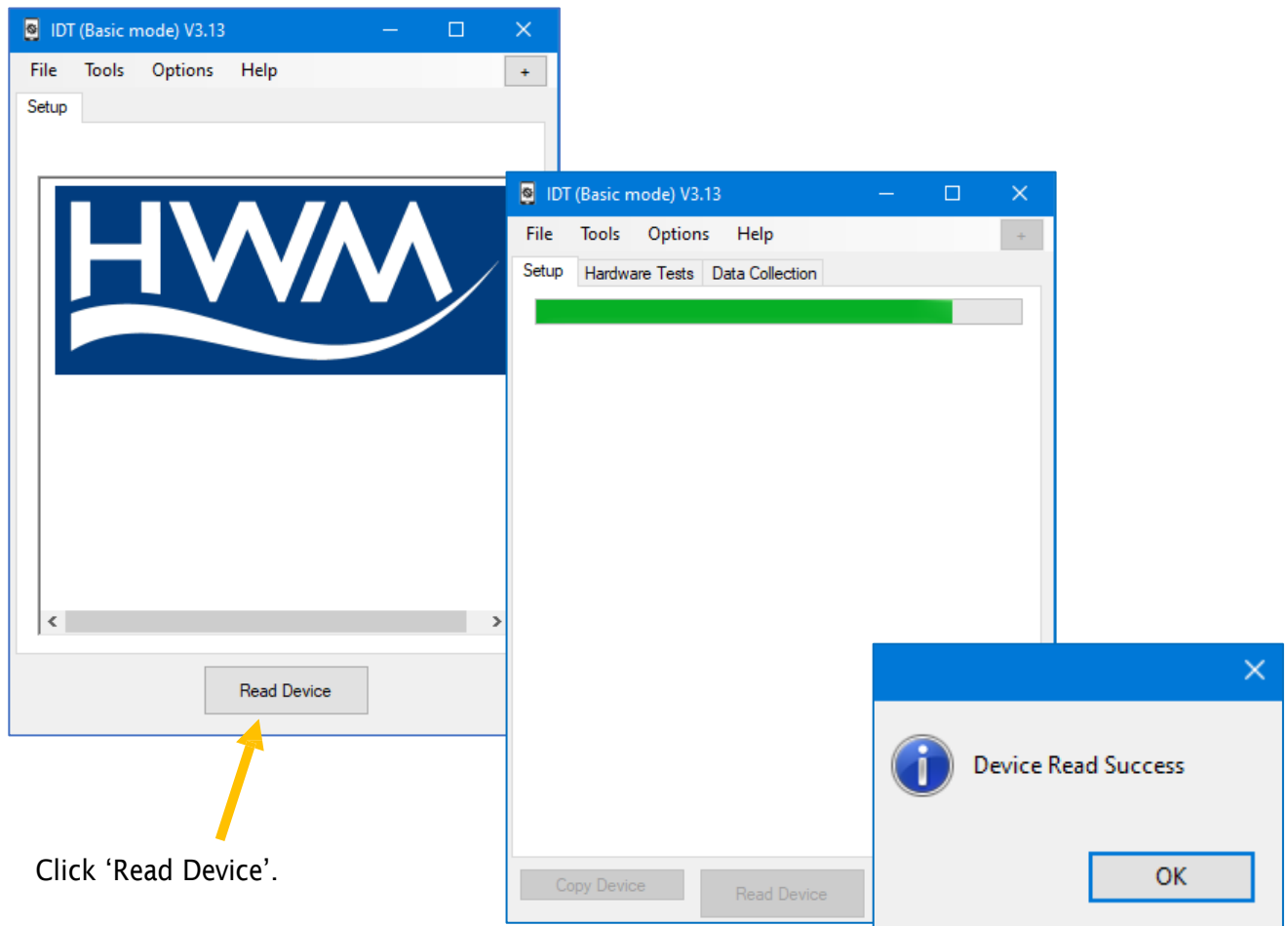

Click 'Read Device'.

A progress bar will show across the top of the page. When completed, an information box will appear stating 'Device Read Success'. Click "OK" to clear the box.

The IDT-PC program has now read the unit's program (settings) in the "current program" memory area. This copy can be edited.

The unit itself is not updated with any of the program changes unless the user later saves the settings stored in IDT back to the Sentinel 2 Control unit by clicking on the "Setup Device" button in IDT.

Setup Device

Some buttons in IDT will however issue commands to Sentinel that can change its operation immediately; others are to control operations of the IDT program.

IDT will now display 4 tabs.

Within any tab, information is divided into various areas, or “panels”.

The “Setup” tab is used for displaying:

- Details of the Sentinel 2 unit.
- The current program settings of the unit.

The panel labelled “Logger” shows:

- The software version running on the unit (here it is shown as V4.88).
- Whether the logger built into the unit is:
  - (Stopped).
  - (Waiting).
  - (Recording).
- The control unit’s serial number.
- The telephone number of the device displays the SIM card number of the device, if factory fitted.
- The logger date and time ... this is the local time for wherever the logger is installed. The offset of local time from UTC is shown in brackets.

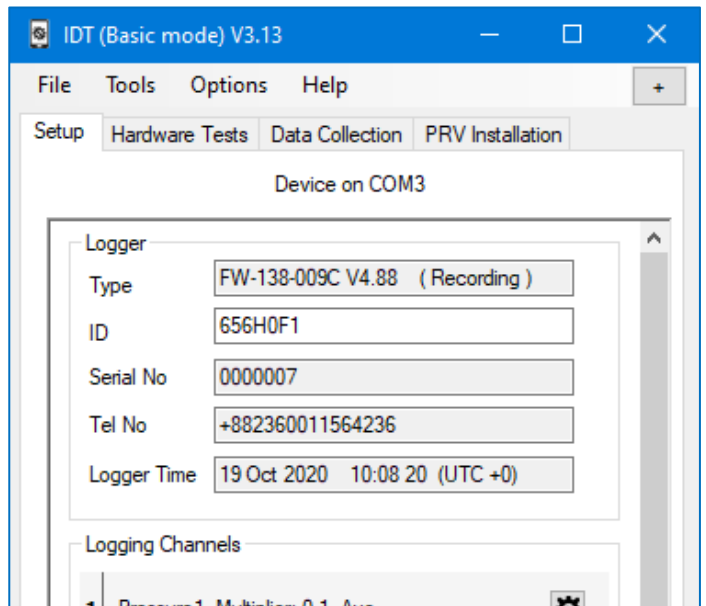

Any greyed-out fields indicates the user cannot adjust them, typically for factory-set parameters. Any non-greyed areas indicate the user can edit the field.

The user can insert a “Site-ID” for this location, which is in the format of a 7-digit reference number.

Other panels (not shown here) follow-on, with settings for various aspects of the unit’s functionality.

The “Hardware Test” / “Data Collection” / “PRV Installation” tabs shown in the above image provide access to information, settings, and control functions available in Sentinel 2 and will be explained later in this manual.

e.g. The “PRV Installation” tab is used during installation.

It can provide live flow and pressure data or manual override controls for various components of the system.

### 2.3.4 Saving settings from IDT into Sentinel 2

When Sentinel is shipped from the factory it is put into a “Shipping Mode” (see section 7.1.2); most functions are deactivated, including the built-in logger, but the unit will detect communications from the IDT tool.

After reading (copying) the current program settings into IDT, the user can modify them (as explained within this manual) and then update the Sentinel 2 by writing back the settings into the unit. This action can also be used to *activate* the built-in logger.

The *running status* of the built-in logger is shown on the top line of the Logger panel (within the setup tab), as shown. Here, it is shown as “Stopped”.

The process of writing settings into a stopped logger will cause it to *schedule a re-start*.

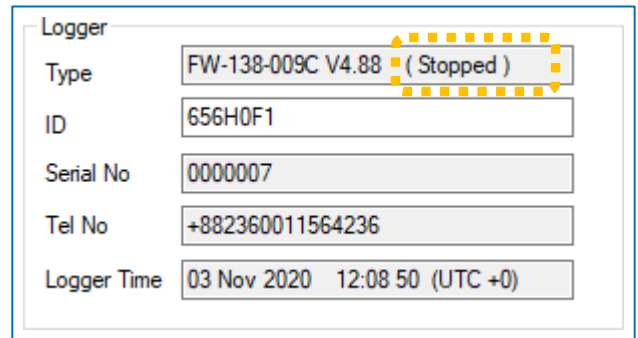

The re-start timing is determined by a setting within the Setup tab. Select “Start Logging immediately”.

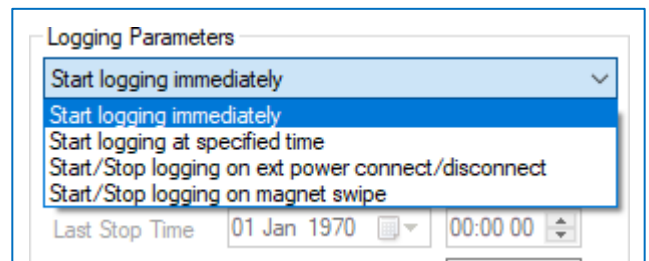

Scroll to the bottom of the Setup tab and click the “Setup Device” button.

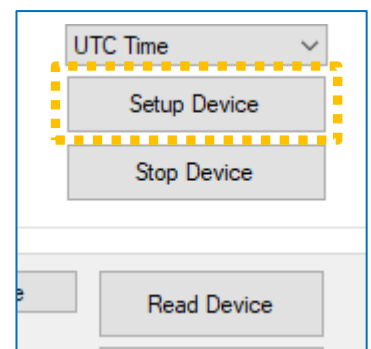

IDT may warn you that there may be some unintended errors in your settings (e.g. see opposite); Since we have not yet set these parameters but will do so later, click “Yes”.

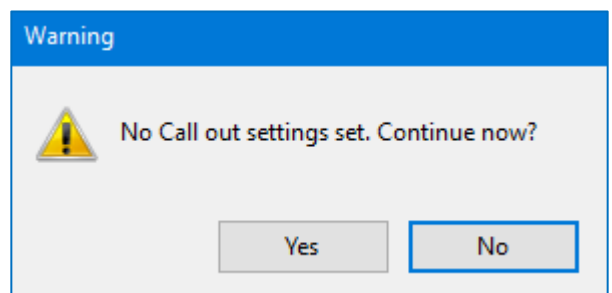

If the PRV control function of Sentinel 2 has not yet been started, IDT will ask if you wish to start it now. Since we have not yet set these parameters but will do so later, click “No”.

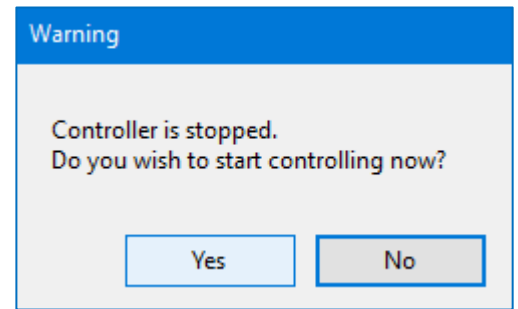

IDT reports that the unit has been given the new settings successfully.

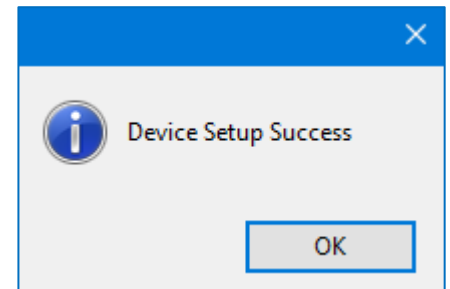

The logger functions have been set to start at a convenient time.

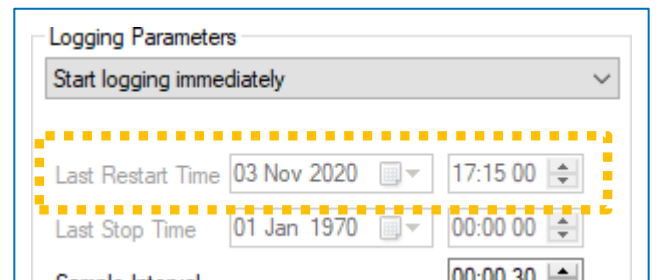

The logger is “Waiting” for the recording start time to arrive.

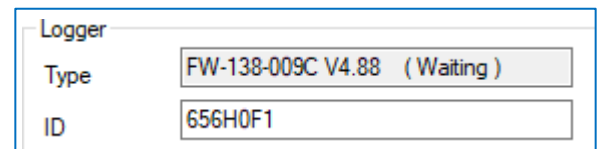

The logger will later begin “Recording”; this is its regular repetitive task.

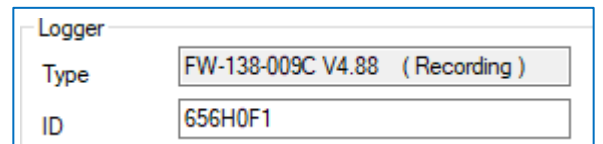

Note: The states for the built-in logger (Stopped, Waiting, Recording) have no effect on the PRV controller operation.

## **2.4 SENTINEL 2 SYSTEM KITS**

Sentinel 2 *systems* can be ordered using a system *kit part-number*.

A kit part-number is used merely for the purpose of ordering several system components under a single part-number. No components will be labelled with the kit part number; Each item will be labelled using its regular part number (as described within sections that follow).

Please discuss any requirements for ordering Sentinel 2 as a system kit with your sales representative.

## **2.5 SENTINEL 2 CONTROL BOX – DESCRIPTION**

Sentinel 2 control box is a combination of a PRV controller and a built-in data-logger.

### **2.5.1 Logger functions**

At the appointed time, the built-in logger will go into the state of “Recording” and begin repetitive logging.

The logger will periodically sample any sensors employed by the PRV controller, but additional sensors can be optionally included in the built unit. These must be requested at the time of ordering; refer to the model-number scheme (see section 2.5.3).

After taking several measurement samples, some statistical functions can be optionally applied to produce a datapoint that is logged (saved); a “point measurement” (a single data sample) can alternatively be saved. The rate at which these are recorded is known as the “log period”, which is always a multiple of the “sample period”.

The datapoints are stored in the memory of the unit. The unit occasionally calls into the cellular data network in order to contact the server; the data is then uploaded.

An installer can also download a copy of the data into the IDT tool for analysis on-site.

The logger can be programmed to monitor data for certain patterns or conditions and to send a message to the server if it should detect a match. Commonly, this is used for setting a condition to be detected by the unit that can be an indication of an “alarm”.

The logger makes measurements (as described above) into an area of memory which is referred to as the “primary recording”. If the logger has the feature enabled, it can also be set to occasionally save additional data into a “secondary recording” memory area, (e.g., data sampled at a higher frequency). This is not available on all supplied units and must be arranged through your sales representative before placing an order; it has implications concerning expected battery life of the unit.

## 2.5.2 PRV Control functions

The unit is shipped from the factory in a low-power mode referred to as “Shipping mode” (see section 7.1.2). The PRV controller is shipped in a nonactive state, (shown within IDT as “No Control”). The installer must activate PRV control at a suitable point during installation by putting the device into the “Start Control” state.

The state of the PRV controller operation has no effect on the built-in logger operation. Operation of the system is described later, in section 2.9.

## 2.5.3 Controller Description

The Control Box unit directs the operation of the Hydros witch unit. The standard configuration includes a flow transducer input which can be included as part of the decision-making process that determines the required pressure output. It also includes pressure measurement interfaces for both upstream and downstream water pressures. Other interface options can be included (at the time of ordering).

An example of a Sentinel 2 Control Box is shown opposite. It contains the following standard interfaces:

- A connector for attachment of an antenna for the cellular data network.
- An electrical MIL-spec connector for the Hydros witch unit.
- A MIL-spec connector for communications and the external battery power option.
- A MIL-spec connector for flow data.  
This measures the rate of flow of water (if a water meter is available on site to connect to).  
(Can be used for control and/or logging purposes).



The example shown contains the following additional interface options (used for logging purposes only):

- A quick-release connector for a water-pressure transducer (or an electrical interface for an external transducer) that usually measures the inlet side of the PRV (upstream pressure).
- A quick-release connector for a water-pressure transducer (or an electrical interface for an external transducer) that usually measures the outlet side of the PRV (downstream pressure).



The front of the Control Box includes a part-number, an example of which is shown opposite:

C163C/656H0F/1/UK1/SH

The part-number is useful to verify the interface content of the unit, summarized as follows ...

<u>Model Number(s)</u>	<u>Description</u>
C163C / * / * / * / S*	Sentinel 2 Controller

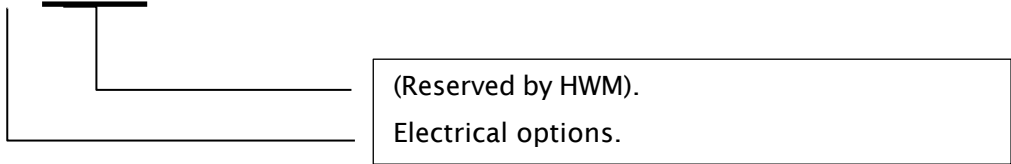

“Electrical options” is a 6-character field, as follows:

c c c H c c (character positions 1 to 6)

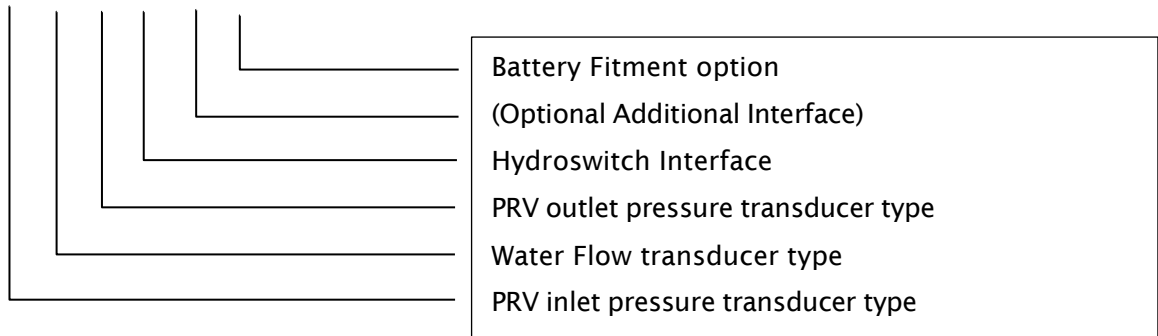

Pressure input (key):

- 3 – External Pressure sensor (electrical interface).
- 6 – Internal Pressure sensor (10-bar) with quick-release connector for water.

Water Flow input (key):

- 1 – Digital Flow Inputs. Maximum of 128 pulses / second from a volt-free output.

Additional Options (key):

- 0 – (Option Not Fitted).
- I – Electrical Interface (I2C).
- M – Electrical Interface (Modbus).
- 5 – Analogue (4-20mA) Flow input (Passive).
- S – Status Input.

Battery Fitment options (key):

- F – Fitted internally and also connected (standard).
- D – Fitted internally but disconnected.
- S – Shipped separately.
- E – Empty. (Fixings for internal battery are supplied, but no battery).
- N – (Nothing supplied: No internal battery. No fixings).

The Front of the Control Box shows standard position for various interfaces. Additional options are not labelled; refer to the guidance given above.

An example of a Sentinel 2 is shown opposite.

The unit includes the options of a Flow interface and 2 internal pressure sensors.

(The unit includes a 3-pin connector for Hydroswitch).

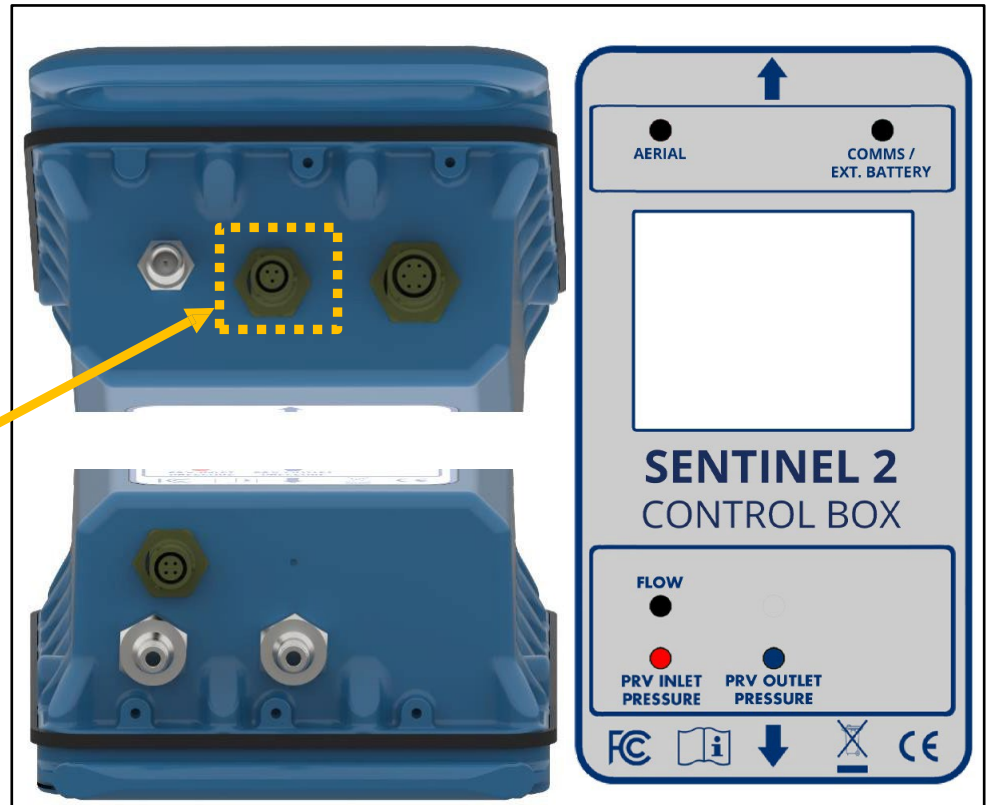

## 2.6 HYDROSWITCH - DESCRIPTION

The Hydroswitch, shown opposite, is a required part of the Sentinel 2 system. It includes a 3-port latching solenoid valve attached via a cable.

The unit attaches to the control box via a built-in cable with MIL-spec connector.



The Hydroswitch is powered by internal batteries. Its operation is directed by the Sentinel 2 Control Box but takes approximately 10 seconds to change.

The valve fitted to the Hydroswitch implements a path changeover between a common port and the other 2 ports, as shown opposite:

The ports of the solenoid valve are not labelled; please refer to the diagrams opposite for standard port use.

The common port is normally connected to the actuator via a 3-way manual valve (tap). The other 2 ports are connected to:

- Pressurized water (port shown as "Pressure Feed") or
- Atmospheric air (port shown as "Vent").

To change from "O" to "A", the manual override must be turned from "O" to "C" and then to "A" : "O → C → A".

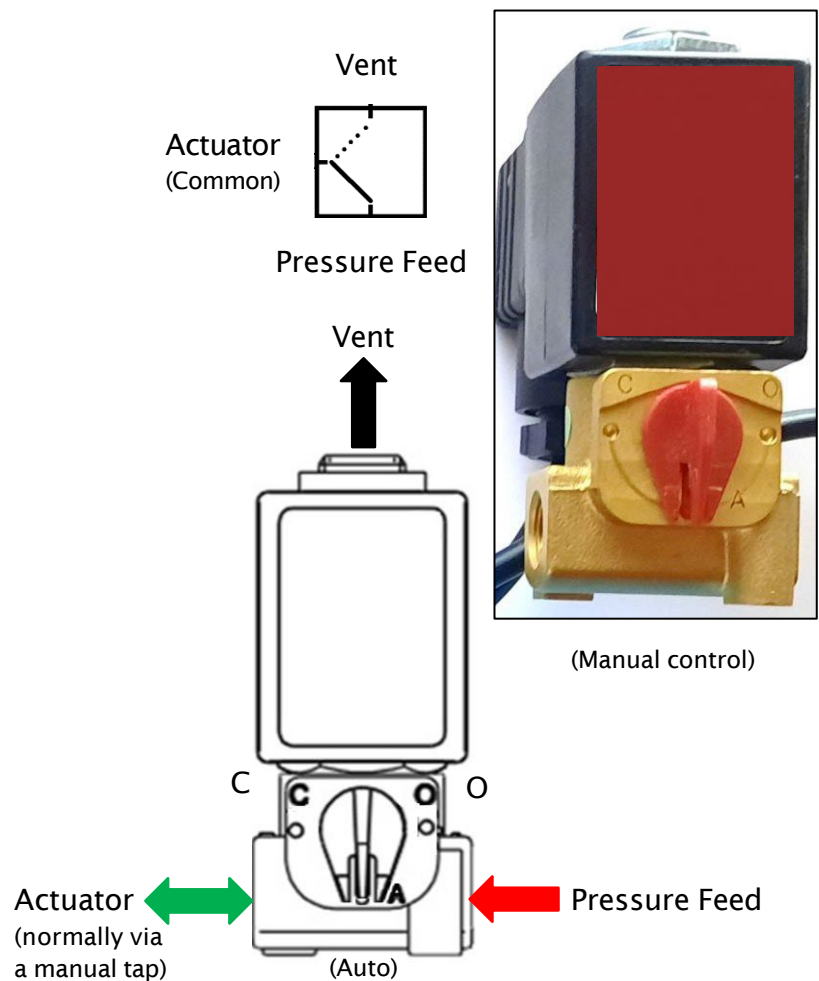

Adapters must be fitted onto the valve prior to connecting the hoses.

When the Hydroswitch is disconnected from the control box it will (after 10 seconds) switch into its default state. This connects a path between the ports labelled Common and Pressure Feed in the above diagram. This default path is also the one that will be active if the Control Box battery fails or some additional fault condition.

The most common system configuration is to require the PRV to go to the high pressure condition should a fault exist in the control box. This will be the assumed requirement for the descriptions within this manual.

Note: Sentinel 2 units can also be *factory configured* to support a low-pressure condition during a fault. This is non-standard and requires changes to installation plumbing and hidden software settings in the Control box. It will not be described in this manual. Please discuss any requirements with your HWM representative.

The diagram opposite shows how to connect the Hydroswitch to the 3-pin connector on the Sentinel 2 Control box.

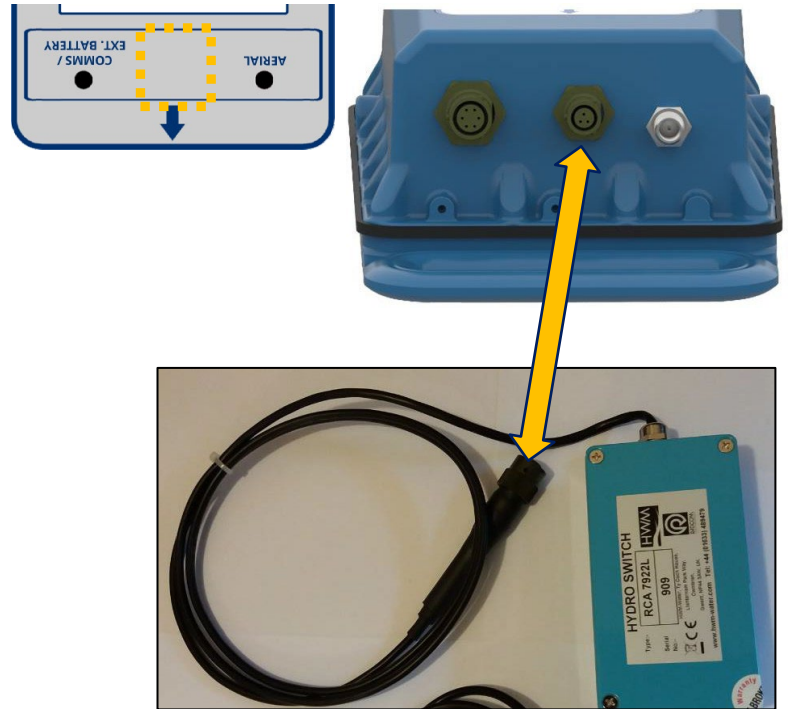

If required, the Hydroswitch can be tested prior to plumbing it into the system:

Connect the communications cable to the Sentinel2, read the settings, and then select the PRV installation tab.

The valve position can be changed by using the controls within the Manual Override panel, located in the PRV Installation tab.

Alternate between setting the target pressure output between Low and High, then clicking the Override button.

The Override will be active for the selected time, then the target setting will return to the regular operation settings.

Note: The Hydroswitch waits for 10 seconds before any change occurs.

Check the valve is switching to confirm it is operating correctly. (It will only switch when the override target pressure does not match the current target of regular operation).

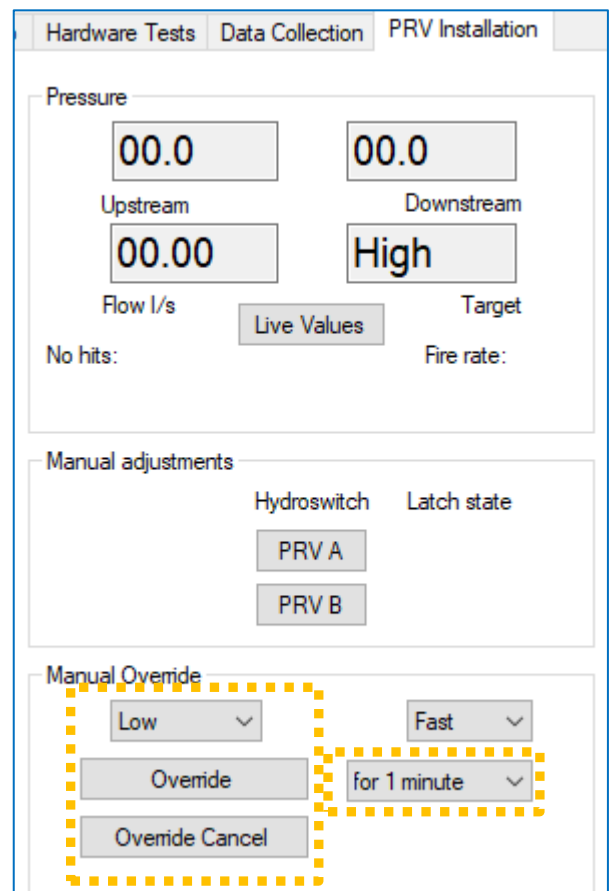

## 2.7 MECHANICAL ACTUATOR

In order to control the outlet pressure of a PRV the Sentinel 2 system is required to modify the PRV behavior so that it produces downstream water pressure which follows the programmed pressure profile. This is achieved with the help of the HWM Mechanical Actuator, shown opposite.

The actuator consists of a diaphragm sandwiched between two concave plates. The one side of the actuator has threaded rod which has been drilled through its length to form a tube. Inside the tube is a plunger which is in contact with the diaphragm. On the other side of the diaphragm, the actuator forms a sealed chamber which can be inflated (or deflated) using hydraulic pressure; hydraulic pressure is supplied through a water-pipe connection, as shown below (via the green hose). The actuator therefore converts an applied hydraulic pressure into the mechanical position of the plunger. The end of the plunger exits the thread.



A PRV normally has its pressure regulated via some control mechanism (which may include a pilot valve), with its outlet pressure being set mechanically; Typically, this is by the manual adjustment of a setting bolt which acts on a spring.

The actuator used within a Sentinel 2 system replaces the setting bolt. It allows the Sentinel 2 to adjust the PRV pressure.



## 2.8 SUMMARY OF PRV FUNCTION (PILOT OPERATED)

(Readers familiar with PRVs controlled by pilot valve operation may skip to section 2.9).

### 2.8.1 Main valve

The main components of a Pressure Reducing Valve (PRV) are shown opposite.

A plunger within the valve body is able to close onto the valve seat (closing off water flow) or open (allowing water flow). Depending on the position of the plunger, the flow has a variable restriction. The restriction reduces the outlet pressure when water is flowing. The plunger position is influenced by the water pressure on both the inlet and outlet sides of the valve seat, internal springs acting on the plunger, and also the position of a diaphragm which is attached to stem of the plunger.

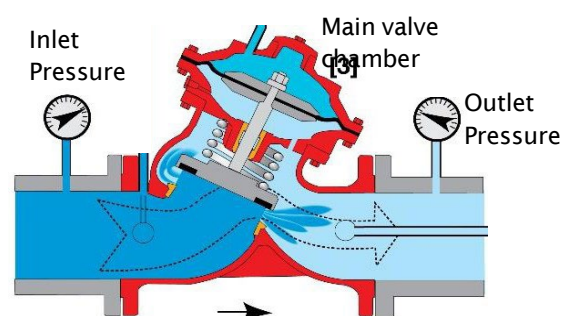

The diaphragm changes position in a manner dependent on the difference in pressure either side it. The pressure on the diaphragm is usually under control of components external to the main valve body, including a pilot valve.

## 2.8.2 Pilot Valve operation

A typical pilot valve is shown in the diagram opposite.

It is constructed with a plunger which has its stem connected to a diaphragm. The position of the plunger is dependent on any forces acting either side of the diaphragm; the force on the lower side being provided by water pressure and the force on the upper side being provided by the compression of a spring. The spring compression can be adjusted by means of an adjustment bolt which re-positions the top seat of the spring.

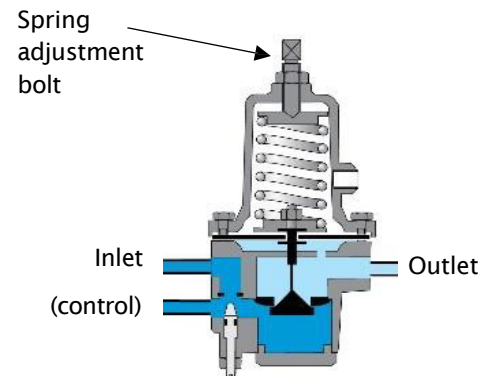

The water flowing into the pilot valve via the inlet port is restricted. This is typically done by a needle valve which may be either internal to the pilot valve or external to it (within the pipe feeding upstream water to the inlet of the pilot valve).

When the pilot valve opens, some of the water flows across the valve (due to pressure difference) and leaves via the outlet port. A 3<sup>rd</sup> port is available, used for control of the main valve.

The needle valve is sometimes referred to as a “speed control”. It prevents damage to the PRV (and water network) by limiting the speed of change to volume of water in the PRV upper chamber.

## 2.8.3 Pilot operated pressure reducing valve

A pilot operated pressure reducing valve automatically and accurately reduces downstream water pressure to a specific, adjustable value.

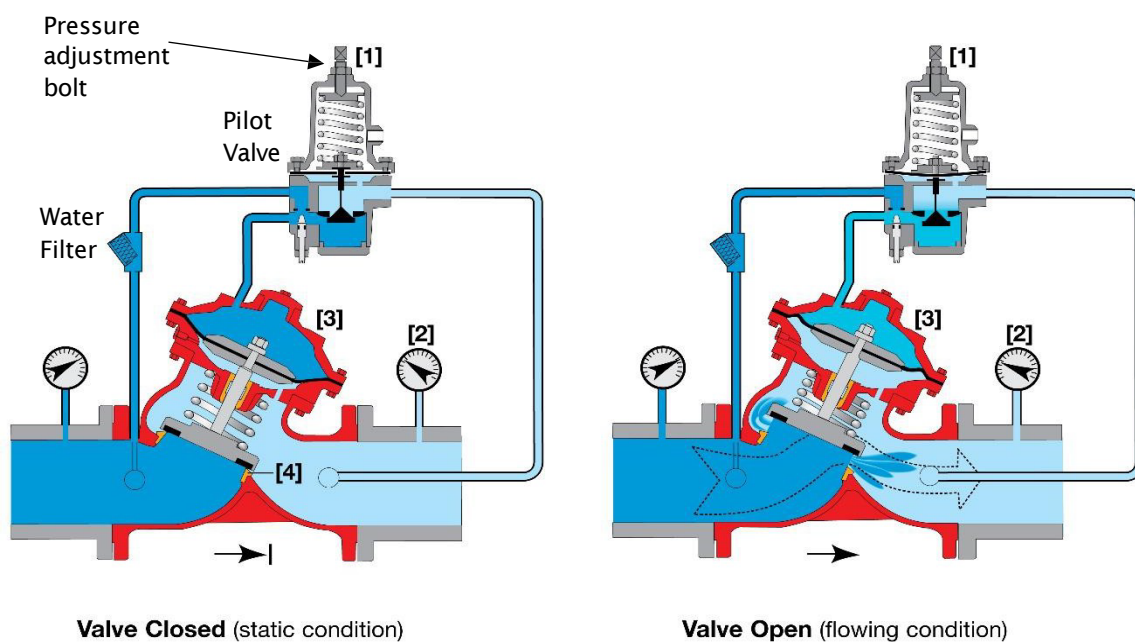



The Pressure Reducing Pilot [1] senses downstream pressure [2] and in real time modulates the top chamber of main valve [3] to maintain a constant downstream pressure.

In no-flow static conditions, should the downstream pressure start rising above the pilot setting, the pilot closes, shutting the main valve [4] to maintain the allowable downstream pressure.

The upstream water is connected to the Pressure Reducing Pilot [1], which is subsequently connected to the top chamber of the main valve [3]. If this pressure is such that the Pilot remains closed, the upstream pressure is the same as the top chamber of main valve pressure. The pressure is balanced, and the valve is closed by the tension in the spring.

Note: The pilot set point is adjusted by turning the pilot adjustment bolt and is not dependent on upstream pressure.

Increasing spring force sets a higher output pressure.

Reducing spring force sets a lower output pressure.

However, if the upstream water pressure in the Pressure Reducing Pilot [1], does allow the Pilot to open, the water exits the valve and becomes downstream water, but more importantly, the pressure in the top chamber of the main valve [3] is now less than the upstream pressure. This pressure differential causes the valve to open.

## 2.9 PRV FUNCTION (UNDER SENTINEL 2 CONTROL)

### 2.9.1 Sentinel 2 Mechanical Actuator

The Sentinel 2 includes the HWM mechanical actuator, which attaches to the top of the pilot valve, replacing the adjustment bolt.

Sentinel 2 is able to control the spring force by adding or removing water from the upper chamber of the actuator. This operates a rod internal to the device (the stem of the plunger) which connects to the seat of the spring.

For 2-point pressure control, Sentinel controls the actuator to change the position of the upper end of the spring. It switches between set limits for either a “High” or a “Low” pressure; the limits are adjustable. The procedure for installing the actuator and setting its limits is covered in sections 4.11 and 4.12.

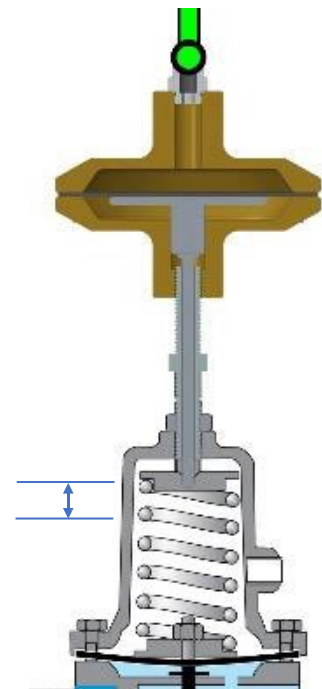

## 2.9.2 Theory of operation (2-point pressure modulation; High and Low)

The plumbing of a Sentinel installation (hydraulic control circuit only) is illustrated below:

The Inlet port connects to the upstream side of the PRV (as long as its pressure is below 90m; see caution note), which provides pressurized water for the system to use.

### **Caution:**

When PRV inlet pressure exceeds 90m, an alternative installation is required...  
Use the downstream water pressure for the Hydroswitch Pressure Feed port instead.

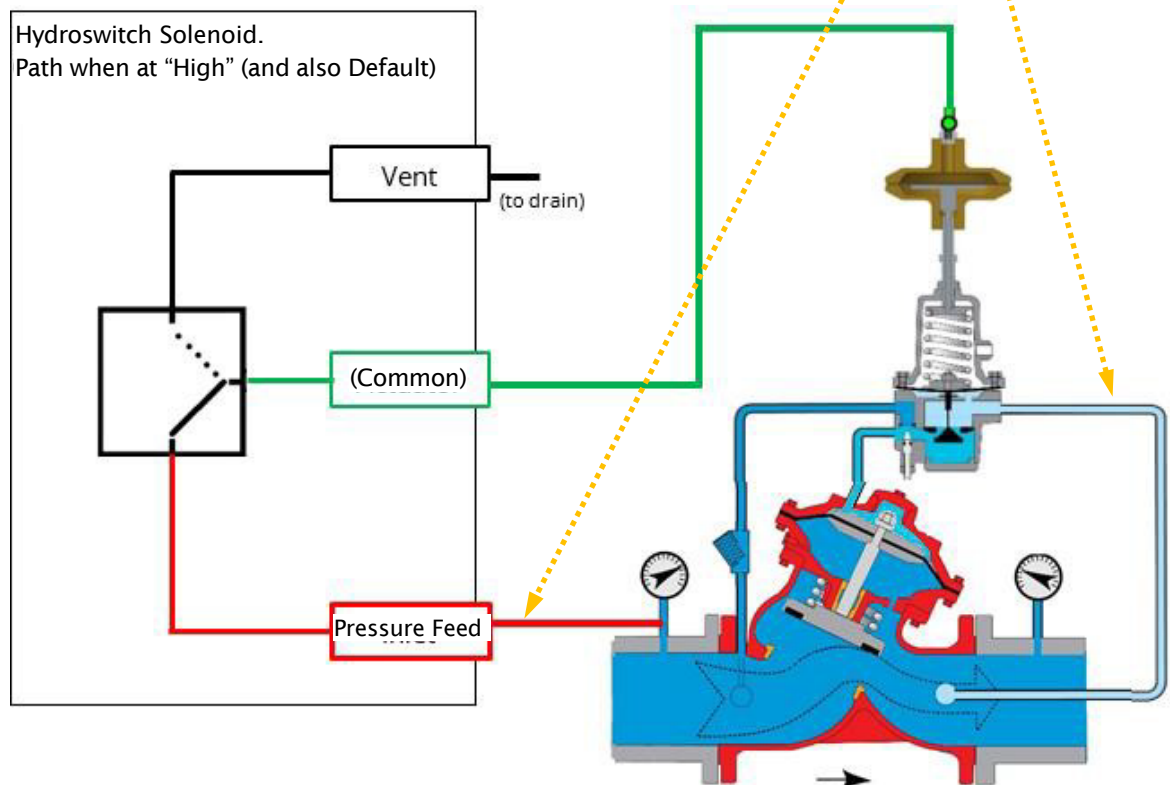

With the valve in the position shown (above), which is the "High" pressure position, the actuator has water pressure applied. The upper chamber of the actuator fills with water, which causes the plunger to depress the spring more. This causes the pilot valve to open more. This decreases the pressure in the lower part of the pilot valve (the PRV pilot rail). This leads to a decrease of pressure in the PRV upper chamber, which causes the main valve to become more open thereby increasing the downstream pressure.



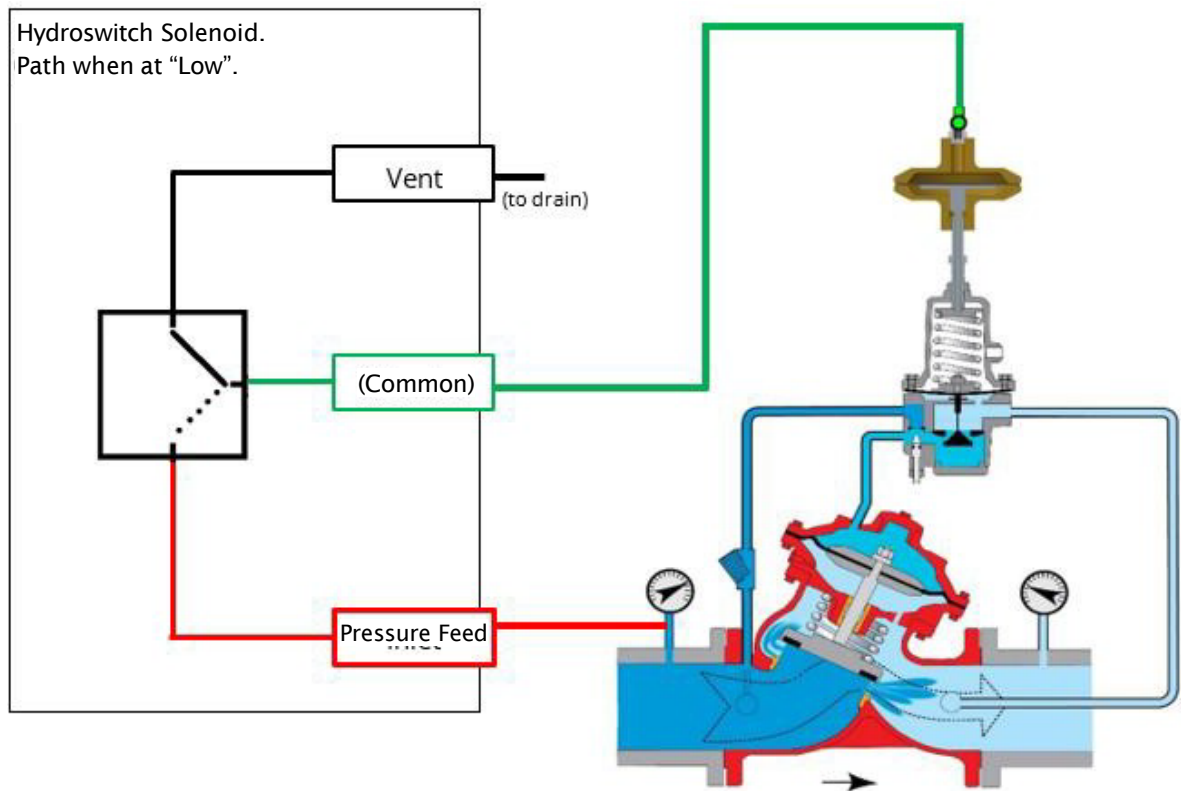

With the valve in the position shown (above), which is the “Low” pressure position, the actuator has no water pressure applied, but instead is vented to atmospheric pressure. The water in the upper chamber of the actuator can escape via the vent pathway, which causes the plunger to depress the spring less. This causes the pilot valve to close more. This increases the pressure in the lower part of the pilot valve (the PRV pilot rail). This leads to an increase of pressure in the PRV upper chamber, which causes the main valve to become more closed thereby decreasing the downstream pressure.

Note: The actuator range of movement is limited by two mechanical end-stops which are adjusted during installation. These set the High pressure and Low pressure output from the PRV.

**Caution:** The PRV pilot rail must include a needle valve that limits the rate of change of the volume of fluid in the PRV upper chamber. The needle valve requires adjustment during commissioning of the system to allow PRV outlet pressure to change over a suitable period (several tens of seconds). This is to prevent damage to the water network or other equipment due to sudden water pressure dips or surges, water-hammer, or other effects.

### 3 CONFIGURATION OPTIONS (DIAGRAMS)

The following sections illustrate some of the possible installation configurations that are achievable using the basic Sentinel 2 system.

#### 3.1 KEY TO COMPONENTS WITHIN THE DIAGRAMS

To assist understanding of the diagrams, details of the various other components surrounding the PRV are shown below.

##### Inlet water filter

Helps prevent blockages due to water quality.



##### 3-way valve

The 3-way valve provides a means to manually switch between control by the Sentinel2 system or an alternative setting (typically used to be able to manually drive the PRV pilot to give a High downstream pressure or safety override).

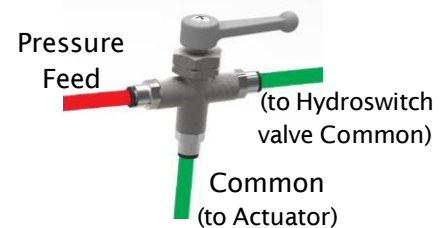

##### HWM mechanical actuator

Provides a means to set mechanical Maximum and Minimum on the pilot.

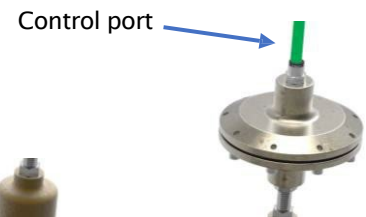

##### Pilot valve

The pilot valve fitted to the PRV.

(Image shown is for illustration purposes only)



##### Needle valve

The needle valve provides a restrictor that slows down the water flow into the PRV upper chamber.

The needle valve is normally situated on the pilot rail.

(Image shown is for illustration purposes only)

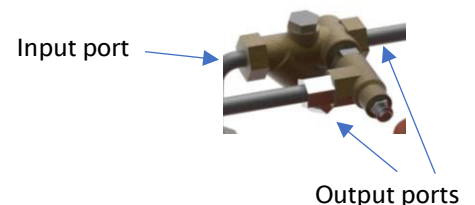

##### Flow meter

The diagrams shows a flow meter (fitted within pipework of the outlet side).

The Sentinel2 system provides models that can interface with various types of flow meters (e.g. Pulse or analogue).

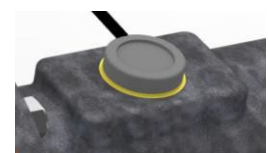

## Pressure Reducing valve (PRV)

The PRV can be fitted with pressure connectors to monitor the inlet and outlet pressure, sometime these access points are on the body of the PRV (as shown in the diagram) or on the pilot or pilot rail.

(Image shown is for illustration purposes only)



## Sentinel 2 Control box

A Sentinel 2 control box is shown opposite.

The unit has an interface for connection to the Hydroswitch unit.

The unit has an electrical connection to an Antenna (not shown).

The unit receives water flow information from a flow meter (not supplied) via a MIL-spec connector labelled “Flow”.

The unit receives upstream water pressure information via the connection labelled “PRV Inlet Pressure”. This could be either via a plumbed-in connection to the water (for a unit which has internal pressure transducers) or via a MIL-spec connector (for installations where external pressure transducers are being used).

The unit receives downstream water pressure information via the connection labelled “PRV Outlet Pressure”. This could be either a plumbed-in connection to the water (for a unit which has an internal pressure transducer) or via an MIL-spec connector (where external pressure transducers are used).



## Hydroswitch Valve

The Hydroswitch valve is a 3-way solenoid valve controlled by the output from the Hydroswitch. It is used to drive the HWM mechanical actuator.

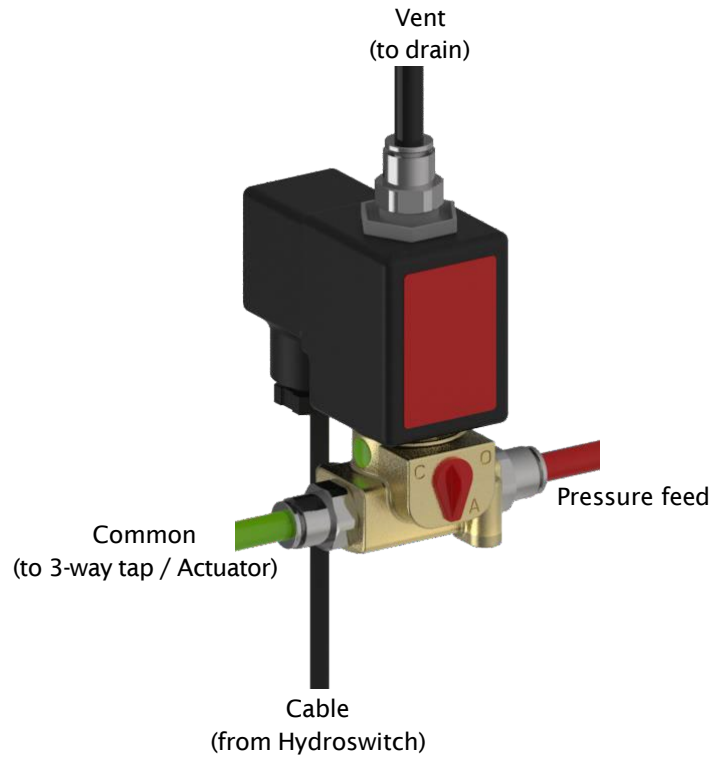

The Hydroswitch valve body is labelled (red and green dots) to assist in identifying the ports during installation.

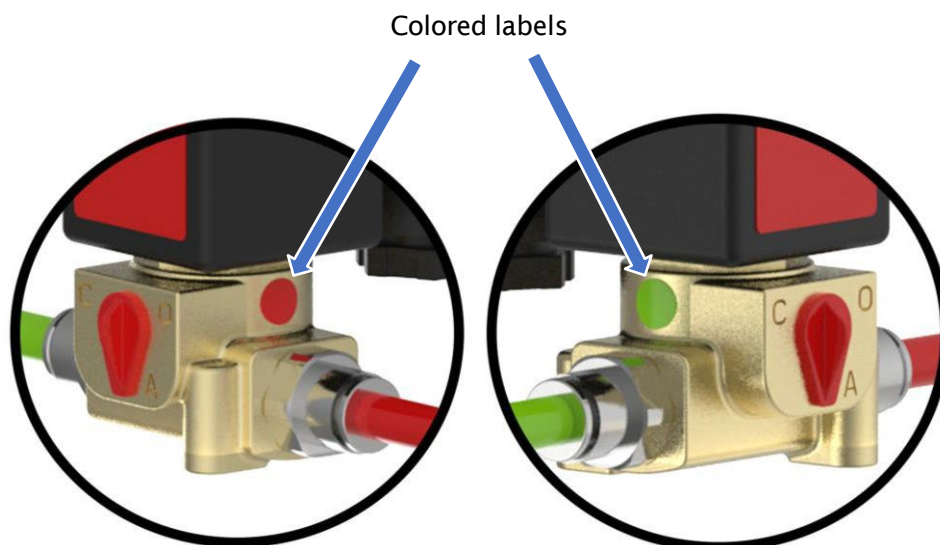

### 3.2 STANDARD INSTALLATIONS: 2-POINT PRESSURE CONTROL

#### 3.2.1 Using: internal transducers (Upstream pressure < 90 m)

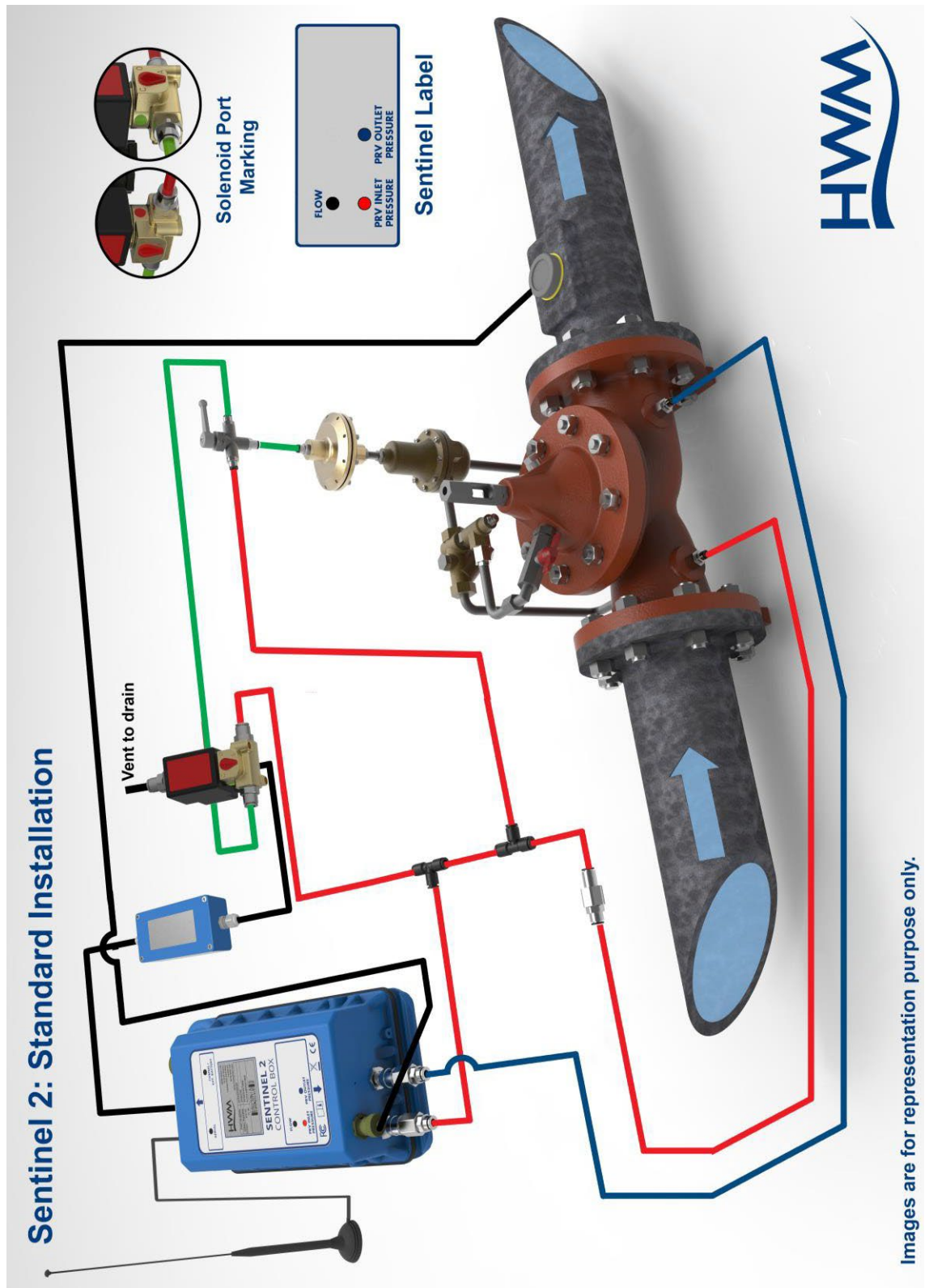



### 3.2.2 Using: external pressure transducers (Upstream pressure < 90 m)

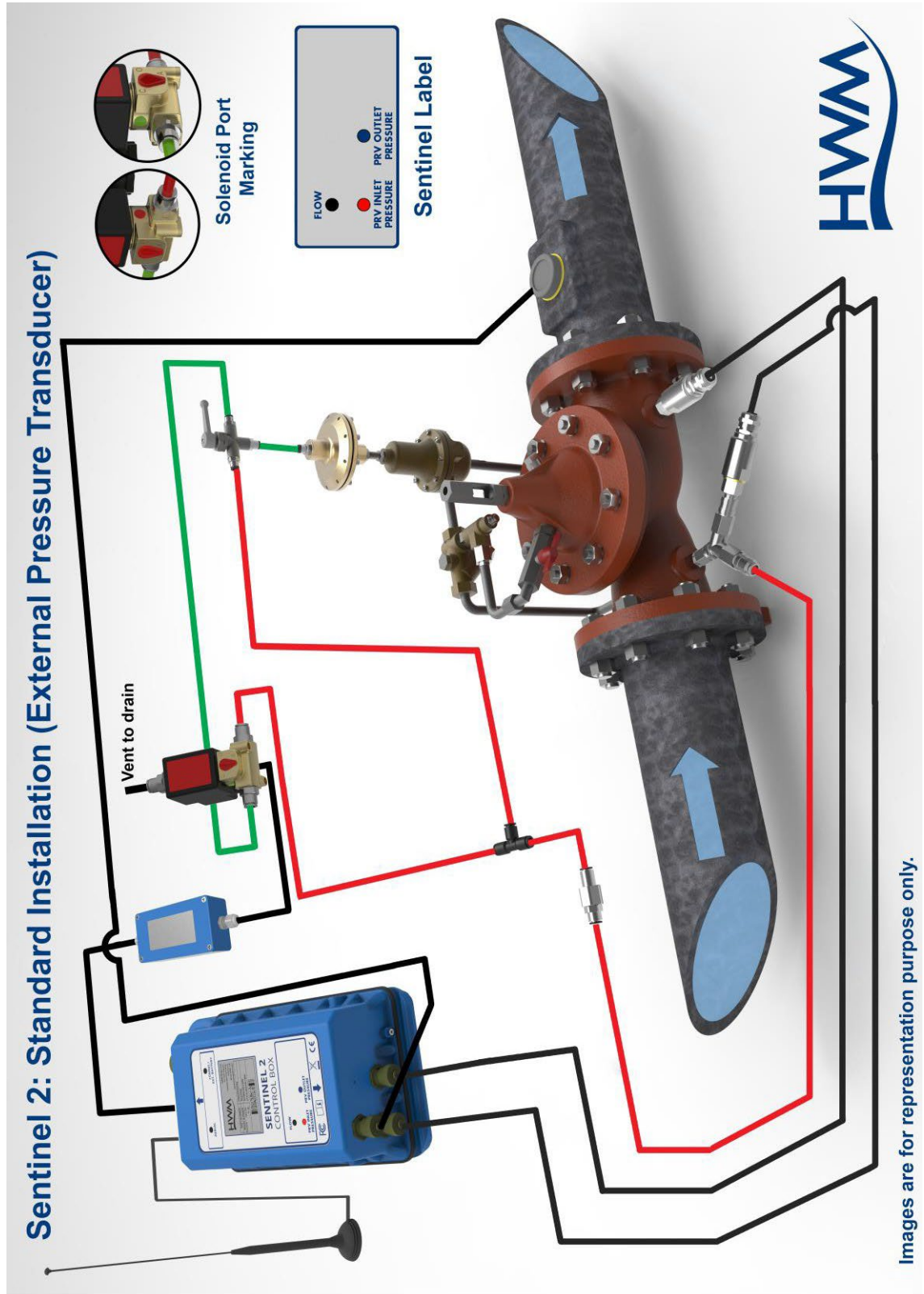

### 3.2.3 Using: internal transducers (Upstream pressure > 90 m)

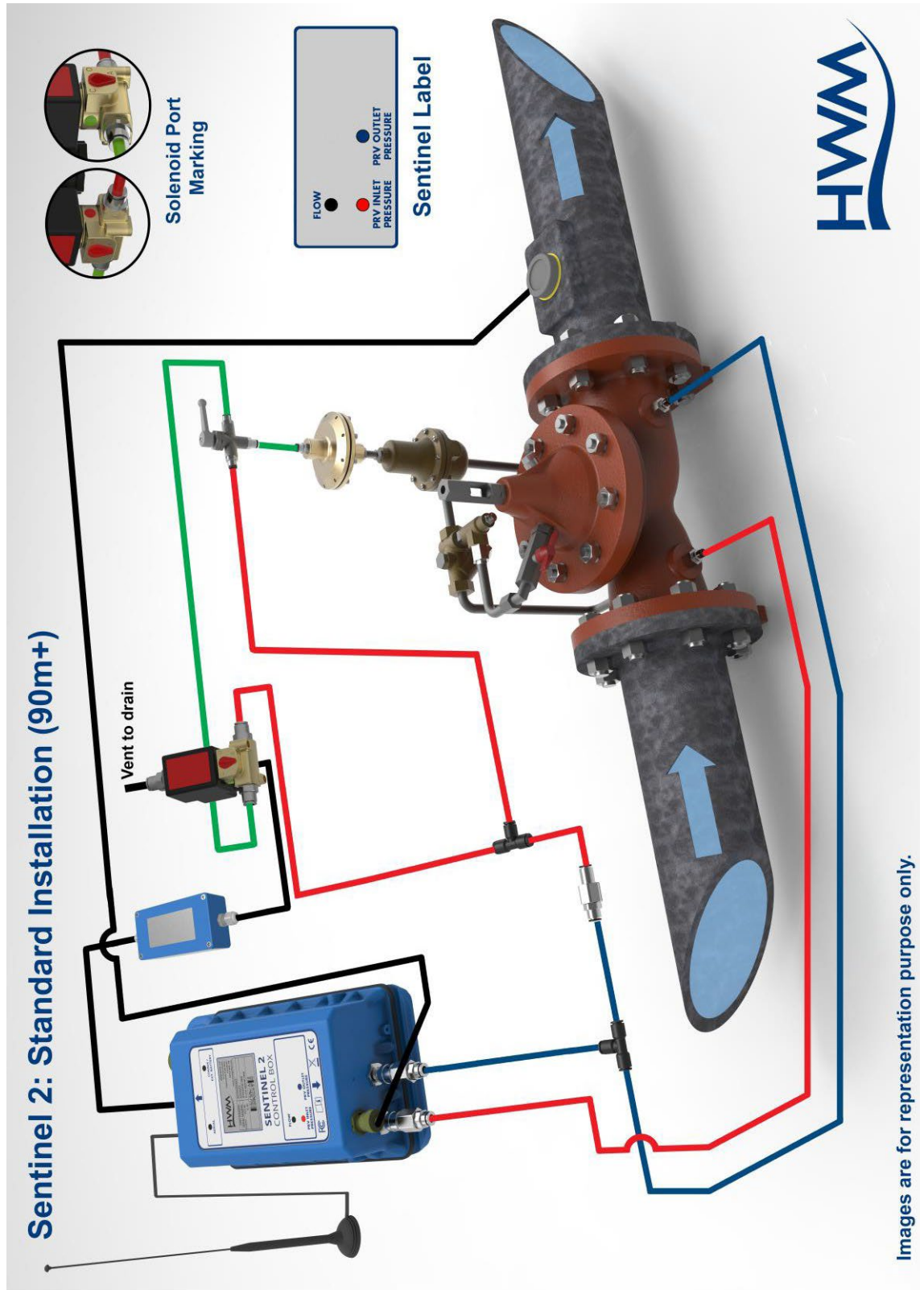

Images are for representation purpose only.

### 3.2.4 Using: external pressure transducers (Upstream pressure > 90 m)

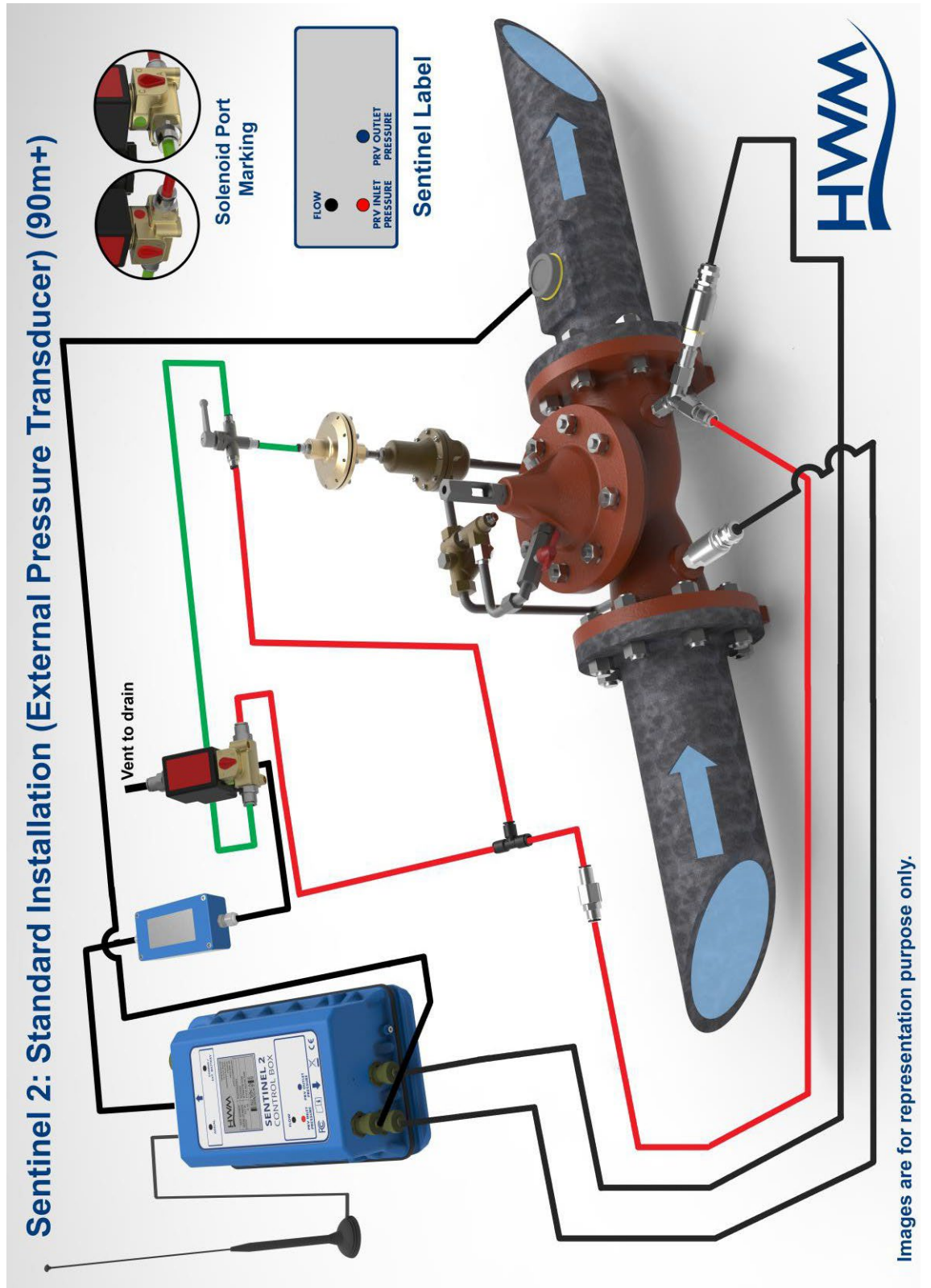



### 3.3 (OTHER INSTALLATION OPTIONS)

#### 3.3.1 Additional Data Logging interfaces

Sentinel 2 includes data-logger functions. Spaces are available to install additional interfaces for data logging. These must be fitted and enabled at the time of manufacture. Select the appropriate model part-number; Refer to your sales representative for assistance if required.

For example, it may be required that an additional pressure transducer be fitted so that the pressure within the upper chamber of the PRV can also be monitored and logged.

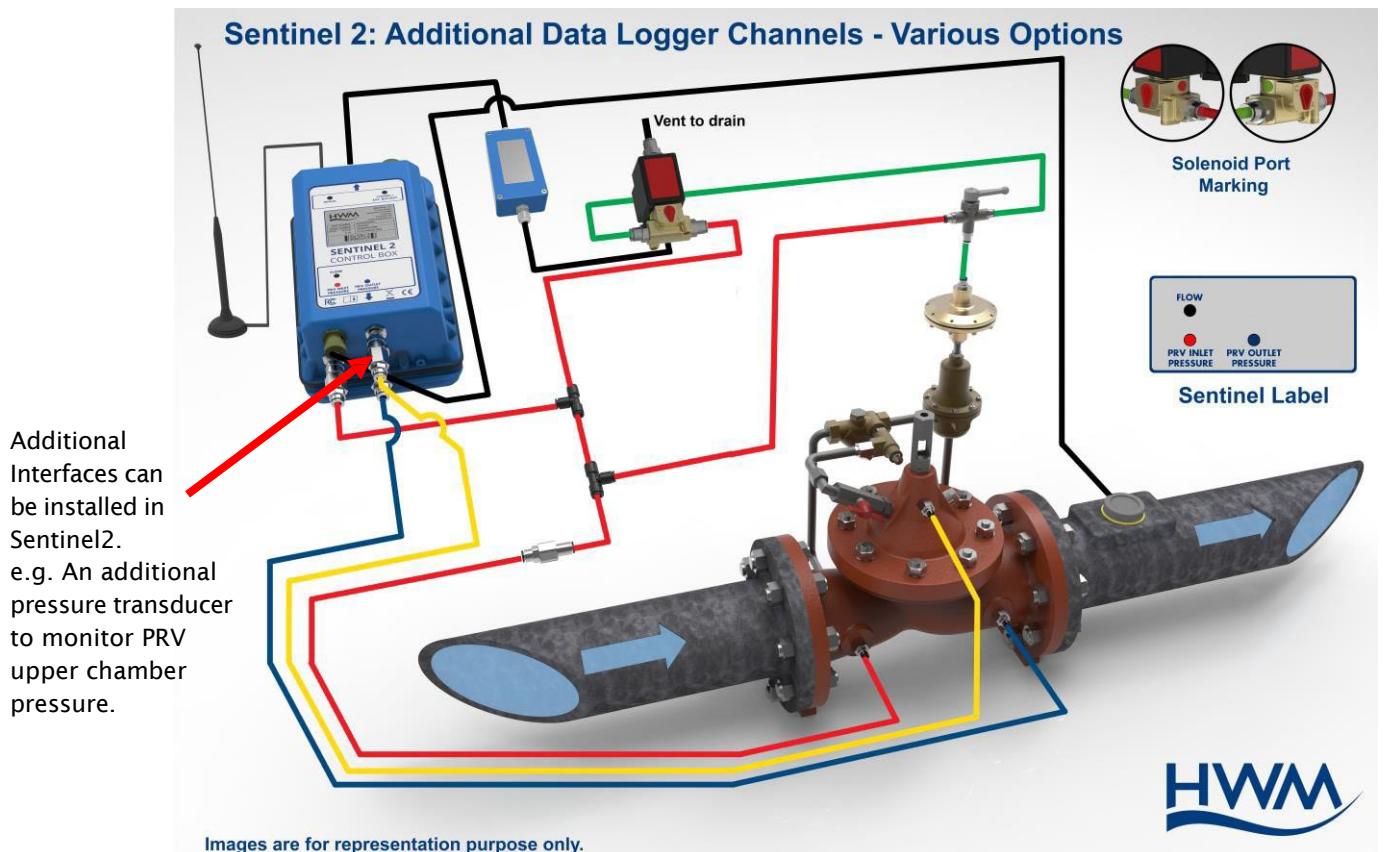

## 4 INSTALLATION PROCEDURE

---

**WARNING:** This equipment should be installed, adjusted, and serviced by qualified water industry maintenance personnel familiar with the construction and operation of the equipment and the hazards involved. Failure to observe this precaution could result in damage to the water network.

The installer will be required to become familiar with the use of IDT as it is used at various parts of the installation process. (e.g., It is required in order to bleed air out of the system, test Sentinel 2 and Hydroswitch operation, and program a Sentinel 2).

### **Summary of system selection and Installation:**

The system can be fitted to an operating PRV, however some flow pressure variation will be experienced whilst testing the system. Installation consists of various activities including:

- Choose a suitable Sentinel2 unit (i.e., model number) for the PRV being controlled and any additional parameters that are required to be logged.
  - The interface for Flow measurements must be compatible with the flow meter. This is a required input for Flow-based pressure control.
  - Pressure measurement transducers must be suitable for the pressure range of the PRV upstream and downstream pressures.
  - To log additional parameters, select a model with the required interfaces.
- Determine the most appropriate control method for the PRV (time, flow or combined time and flow).
- Select an appropriate connection scheme for the PRV and ensure pipes and accessories are available; Refer to the example installation diagrams within this guide. Pay attention to the plumbing differences required if the upstream water pressure exceeds 90m.
- Choose suitable positions and mounting method for the equipment including the antenna; Fix in location and connect any cables.
- Attach a communications cable between Control Box and PC for set-up of the system.
- Program the required pressure profile and other settings into the Sentinel.
  - Read the current configuration.
  - Test the Hydroswitch prior to plumbing it into the PRV control.
  - Make any changes required to the on-screen settings.
  - Program the Sentinel 2 with the on-screen settings.
  - Re-zero any pressure transducers at atmospheric pressure (not water pressure).
- Fit the mechanical actuator onto the PRV pilot. Set the range of the actuator (required mechanical adjustment) to maximum and minimum required pressures.
- Plumb the Sentinel system into the PRV. Connect any transducers.
- Activate the Sentinel to begin logging measurements and controlling the PRV.
- Adjust the needle valve as required for gradual water pressure changes when switching between high and low pressures.
- Bleed and test the operation of the system.
- Test communication with the central computer is OK (i.e., a call-in test).

## 4.1 POSITION CONTROL BOX AND HYDROSWITCH / CONNECT.

The Sentinel 2 Control Box can be secured to a wall using an optional bracket, shown opposite.

Ensure the wall and fixings used are able to bear the weight of the Sentinel 2 and any cables.

All cables should be routed and secured in a way that avoids stress being put on the connectors.



### 4.1.1 Antenna

Attach the antenna to the connector labelled “Aerial”.

The bracket offers a potential mounting location for the antenna, as shown, although the installer should seek to find the optimal location for the antenna within the installation (see section 4.21).



### 4.1.2 Battery

If the system is to be installed with an external battery (optional, but sometimes required to increase the length of service of the system), mount it in a suitable location near the control box. It must be connected to the Control box via the connector labelled “Comms / Ext battery”.

The external battery may be temporarily disconnected during parts of the installation (whilst the Comms cable is required to be used) but must be re-connected at the end of system installation.

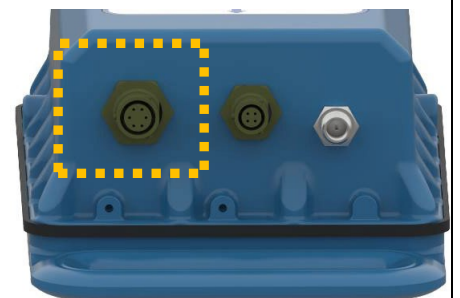
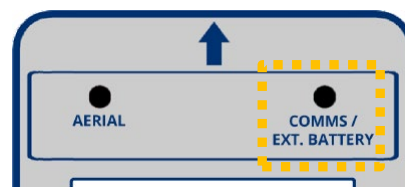

### 4.1.3 Hydroswitch

Connect the Hydroswitch to the Sentinel Control box. (Refer to section 2.6)

## 4.2 CONNECTION TO THE FLOW METER

Connection to the flow meter is required for any Sentinel 2 that uses a pressure profile that is dependent on flow (i.e., flow or combined time and flow).

For other situations it is optional and will be used only by the data-logger functions.

The water flow can be detected by a flow meter near the PRV. The Flow information is transferred to Sentinel 2 by means of an electrical interface in the Control Box.

Various hardware interfaces exist for collecting flow information, including:

- Collection of meter pulses (from a contact or a volt-free pulse output). This type of interface is suitable for supporting the PRV control functions. (Refer to section 6.1.1 for cable diagram).
- Analogue (4-20mA) input for connection to a compatible output of a flow meter. This type of interface is **unsuitable** for supporting the PRV control. It can be used as a measurement interface option for logging purposes only.

Connect the Flow-meter end of the cable to the flow meter.

Then connect the cable to the Control box via the 4-pin connector labelled “Flow”.

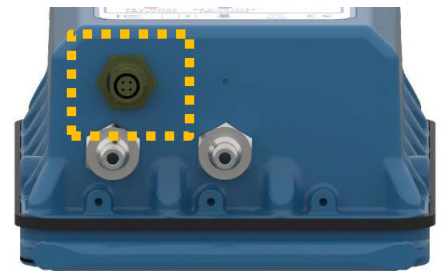
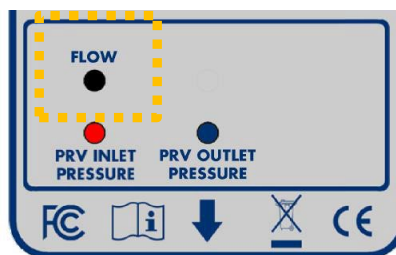

## 4.3 CONNECT EXTERNAL PRESSURE TRANSDUCERS TO SENTINEL 2

Where the Sentinel 2 is supplied with external pressure transducers, these must be connected to the relevant MIL-spec connector on the control box.

Determine which transducer will be used for measuring upstream pressure and which will be used for measuring downstream pressure. Check the range of each transducer is suitable for use (refer to the label on the cable of HWM supplied external transducers, as described in section 4.4).

Plug each transducer into the correct Sentinel 2 MIL-spec connector:

- Be sure to connect the upstream pressure transducer to the connector labelled “PRV Inlet pressure”.
- Be sure to connect the downstream pressure transducer to the connector labelled “PRV outlet pressure”.

Ensure connectors are correctly fitted so that they are watertight.

## 4.4 CHECK / MODIFY SENTINEL 2 CHANNEL SETTINGS

In order for Sentinel 2 to operate correctly, any input channels must be set up, along with any calibration data and also various other settings.

Select the Setup tab in IDT. Scroll to the “Logging Channels” panel.

This panel gives information regarding the type of interfaces for transducers fitted into the unit.

Electrical interfaces can sometimes be general-purpose in nature, so the unit has to be informed (by settings) of what type of transducers are attached. Also, it needs to be informed of how to interpret numeric readings into physical measurements.

The diagram opposite represents the transducers as inputs to a data-recorder which has several channels of recording memory. i.e., it is arranged as a set of “logging channels”.

The channels may be pre-configured by the factory prior to shipment, but the installer is responsible for confirming it is correctly configured to suit the installation site.

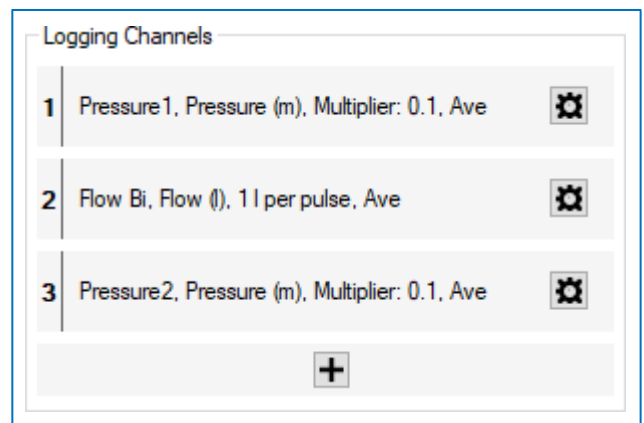

Channels can be added using the “+” button (e.g., if other optional interfaces are fitted).

To modify an already existing channel, click on the relevant settings (cog) button.



For Sentinel 2 to operate correctly, the channels (where used) must always be set to the following units of measure:

- Pressure: meters ... although inputs work in raw units of decimeters (1/10 m).
- Flow: liters per second.

For Sentinel 2 to operate with the DataGate and PressView websites, the unit must always be set up with data presented to the unit’s built-in logger using the following channels:

- Channel 1: PRV inlet pressure (upstream pressure).  
Sentinel2 uses the “Pressure 1” type of interface for this connector.
- Channel 2: Flow.  
Sentinel2 uses one of a set of interface types for this connector.  
Each interface expects a voltage-free pulse output from the Flow meter.
  - Flow Uni (for a Unidirectional Flow meter)
  - Flow Bi (for a Bidirectional Flow meter)
- Channel 3: PRV outlet pressure (downstream pressure).  
Sentinel2 uses the “Pressure 2” type of interface for this connector.

**Example 1:**

Setup of the pressure transducer for “PRV Inlet pressure”.

Note: The PRV inlet pressure is required by Sentinel 2 (and also PressView) to be mapped to “channel 1”.

Clicking the cog button for channel “1” gives details of the source of measurements that will be used for the “channel 1” memory area. It should be modified if required.

In our example, the pressure transducer is internal and has a range of 0-10 bar (0-100m).

Note: The pressure range can be found from examination of the model number for internal transducers, or a calibration details label on the cable of external transducers supplied by HWM.

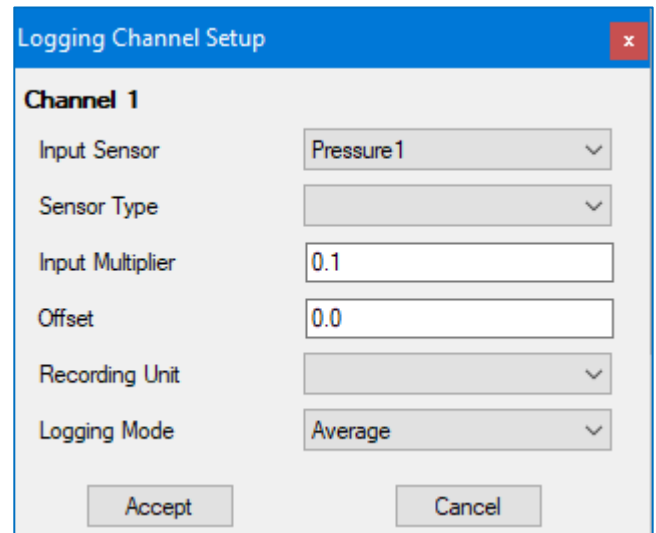

Our example unit, Sentinel 2 unit has 4 available input transducers (input sensors):

- Pressure1: An internal pressure transducer (located at the port labelled “PRV inlet pressure”).
- Flow Bi: An electrical interface for a flow meter that has a compatible electrical interface i.e., a volt-free pulse output.
- Pressure2: An internal pressure transducer (located at the port labelled “PRV outlet pressure”).
- Temp Int: A transducer that can measure the internal temperature of the unit.

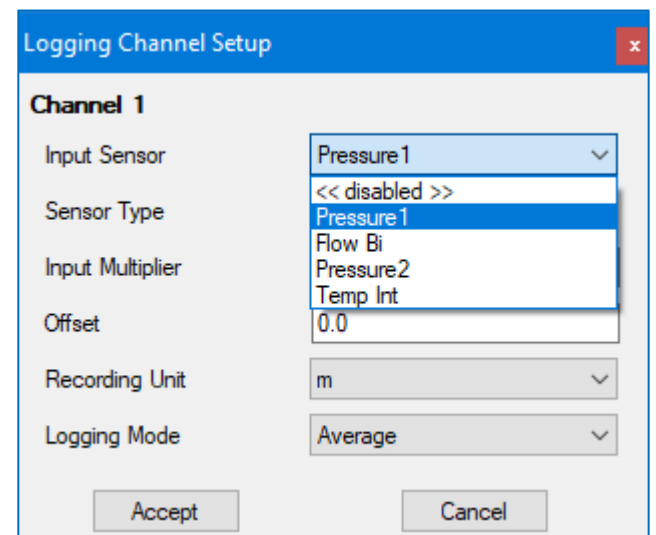

The “Input Sensor” drop-down selector is used to choose the electrical interface for the channel 1 logging memory area.

Select “Pressure1”.

The “Sensor Type” drop-down selection box starts the configuration of how numerical measurements from this interface will be interpreted.

The pressure interface should be interpreted as a reading of “pressure”.

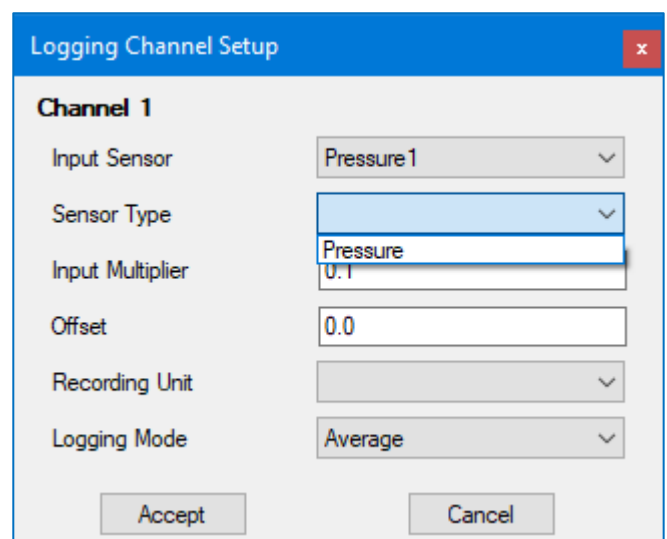

Selecting the above makes available the relevant units of measure for “pressure”.

Choose the unit of measure from the list available in the “Recording unit” selector.

Sentinel 2 and the PressView website both require the Recording unit to be “m” for correct operation. Select “m”.

The appropriate scaling factors (multiplier and offset) are also required.

Offset is usually “0”.

For Sentinel 2, calibration factors for internal pressure transducers are applied in production, such that each digit change represents a decimeter of pressure (1/10 of a meter).

Or, put another way, the number obtained when the interface is read has to be multiplied by 0.1 to convert it to meters (m, the selected recording unit).

“Input multiplier” is therefore set “0.1”.

The “Logging Mode” should be set at “average” for Sentinel 2; this will smooth-out any noise (short fluctuations) in the readings and give a representative value of pressure.

When completed, click on “Accept” to update the configuration being stored the IDT-PC “current program” memory.

The channel settings are summarized in the “Logging Channels” panel.

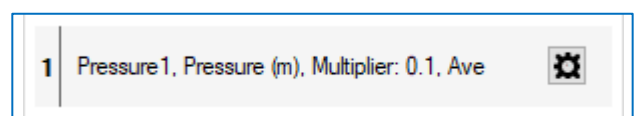
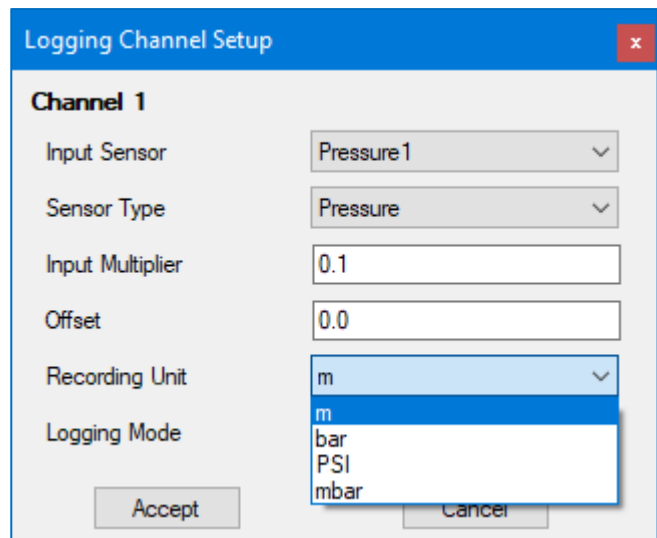

Note: External pressure sensors supplied by HWM for use with Sentinel 2 will behave similarly once the calibration factors supplied on the label of the transducer cable have been applied. (i.e. They will measure in decimeters and require an Input multiplier of “0.1” when converting to meters).

Other pressure channels can similarly be checked or set up by first clicking the relevant setup icon.



**Example 2:**

Setup of the interface for “Flow”.

Note: The Flow input is required by Sentinel 2 (and also PressView) to be mapped to “channel 2”.

Clicking the cog button for channel “2” gives details of the source of measurements that will be used for the “channel 2” memory area.

It should be modified if required.

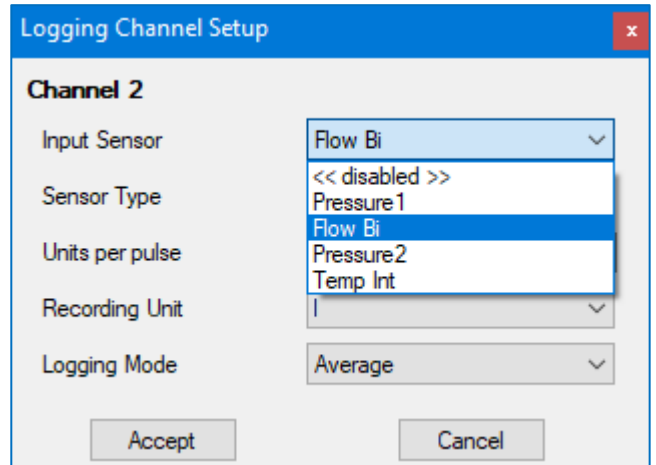

The Flow input for Sentinel 2 PRV control is required to be a volt-free pulse input. This could be one of the following:

- Flow Bi (for a Bidirectional Flow meter), as in this example or
- Flow Uni (for a Unidirectional Flow meter)

The “Input Sensor” drop-down selection box is used to choose the electrical interface for the channel 2 logging memory area.

Here we have selected “Flow Bi”, which will work with a bi-directional flow meter.

The “Sensor Type” drop-down selection box starts the configuration of how numerical measurements from this interface will be interpreted.

The Flow interface should be interpreted as a reading of “Flow”.

Selecting the above determines what units of measure are available for “Flow”.

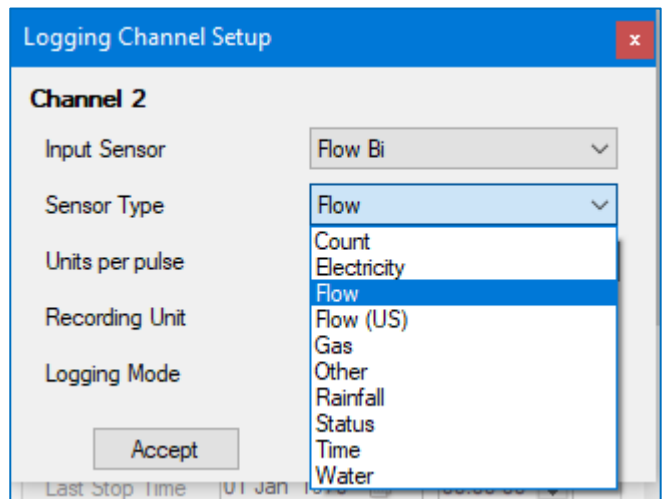



Choose the unit of measure next from the list available in the “Recording unit” selector.

Sentinel 2 and the PressView website both require the Recording unit to be “l” for correct operation.

Sentinel counts the meter pulses over a logged period and converts them into a “liters per second” measurement. Sentinel uses the units of liters / second as part of its evaluation of whether to adjust the PRV setting (if flow control is set).

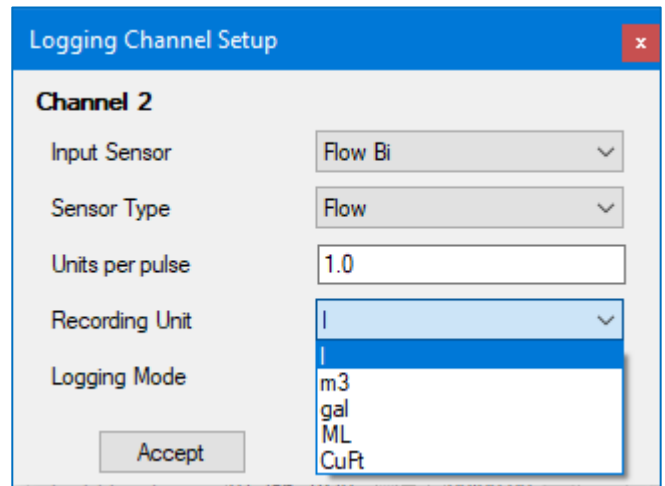

Logging Channel Setup

Channel 2

Input Sensor: Flow Bi

Sensor Type: Flow

Units per pulse: 1.0

Recording Unit: l

Logging Mode: [dropdown menu]

Accept

The appropriate scaling factor (Units per pulse) are also required.

e.g. If 1 pulse represents 10 liters, “Units per pulse” should be set to “10”.

“Logging Mode” should be set at “average” for Sentinel 2; this will smooth-out any noise (short fluctuations) in the readings and give a representative value of flow.

When completed, click on “Accept” to update the configuration being stored the IDT-PC “current program” memory.

The channel settings are summarized in the “Logging Channels” panel.

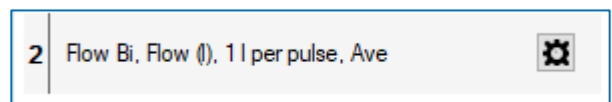

2 | Flow Bi, Flow (l), 1 l per pulse, Ave

Note: Optional additional channels can be set in a similar manner to the 2 examples.

Decide if any statistical filtering will be applied to the incoming channel data stream for creating datapoints in “logged data” memory.

- Average (of a set of measurements)
- Minimum (of a set of measurements)
- Maximum (of a set of measurements)
- Spot (a single measurement)

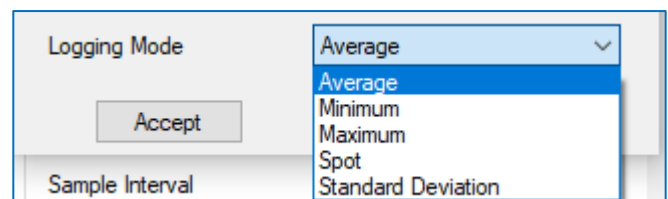

Logging Mode: Average

Accept

Sample Interval

## External Pressure Transducers – Entering Calibration coefficients

External pressure transducers from HWM have calibration coefficients that must be entered into IDT in order for Sentinel 2 to use them correctly.

Enter the values, as per the example opposite (including any negative symbols).

Note: The final number represents the *maximum pressure range* of the transducer (in bar).

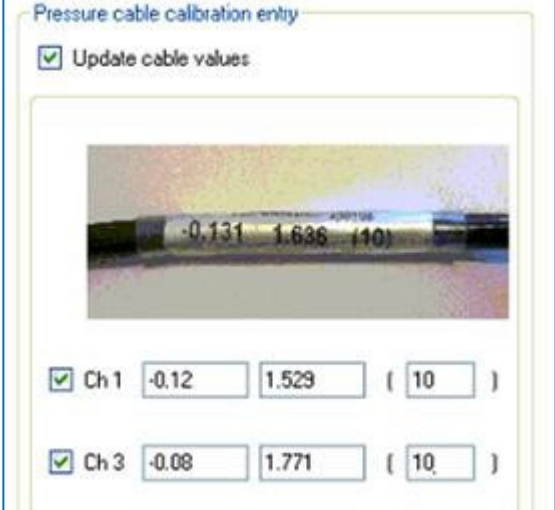

Pressure cable calibration entry

Update cable values



Ch 1 -0.12 1.529 ( 10 )

Ch 3 -0.08 1.771 ( 10 )

At this stage, it is important that the channel settings stored in the PC memory should be written into the Sentinel 2.

Scroll to the bottom of the Setup tab and click “Setup Device”.

(The unit will now operate with the channels as set earlier).

Re-load the program into IDT by clicking the “Read Device” button.

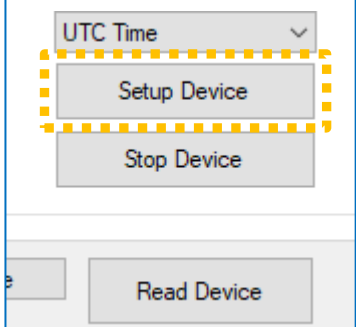

UTC Time ▾

Setup Device

Stop Device

Read Device

## 4.5 RE-ZERO PRESSURE TRANSDUCERS

Ensure any external pressure transducers are connected to the Sentinel 2 at this stage.

- Be sure to connect the inlet pressure transducer to the connector labelled “PRV Inlet pressure”.
- Be sure to connect the outlet pressure transducer to the connector labelled “PRV outlet pressure”.

Ensure connectors are correctly fitted so that they are watertight.

The transducers (internal or external) must now be re-zeroed whilst in **atmospheric pressure** (not connected to water pressure).

Select the Hardware Tests tab in IDT and click the “Re-Zero” button.

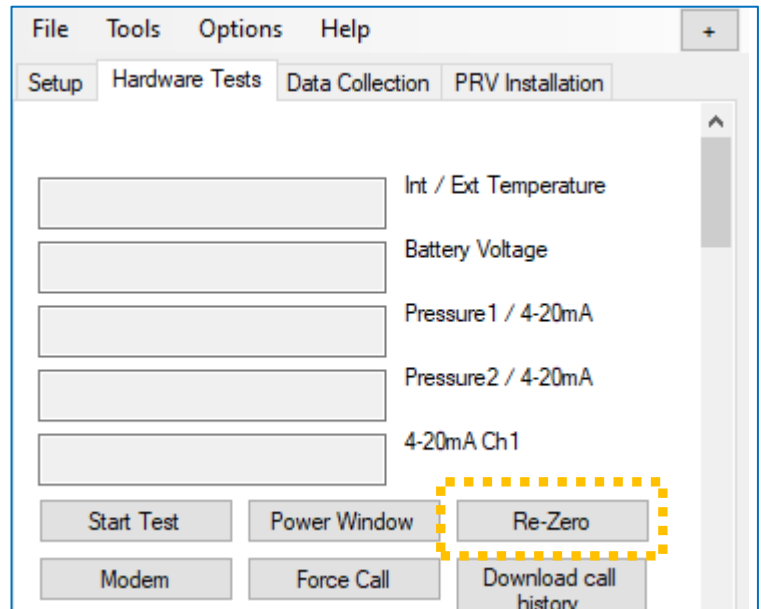

Select the “PRV Inlet pressure” transducer by picking “Channel 1” on the drop-down control.

Then click “OK”.

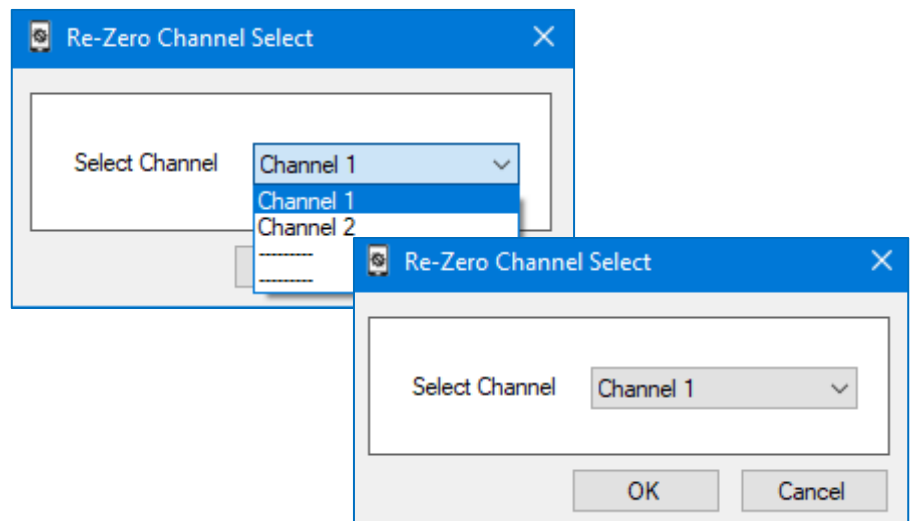

This starts the re-zeroing process of the Sentinel 2, which repeatedly reads the numeric output from the transducer.

...Wait for this to stabilize (e.g. wait for 10 readings) and then click the "Save" button.

The value is stored.

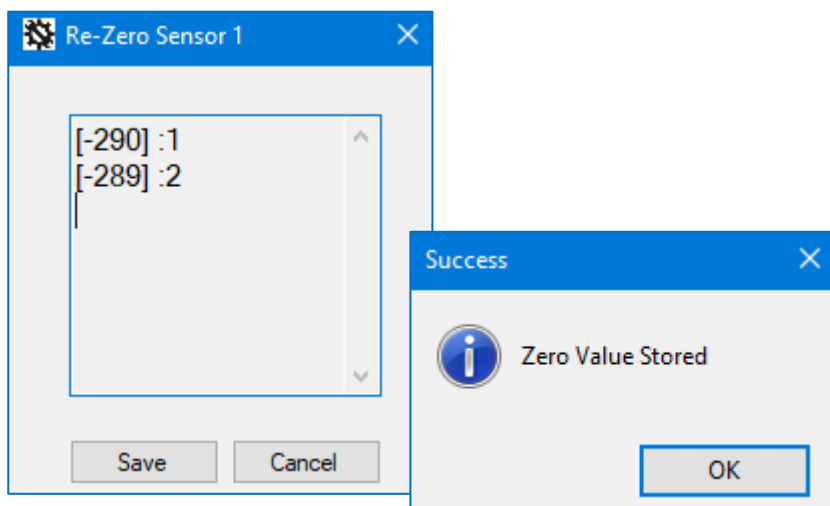

Note: If the value does not stabilize and is showing readings with a difference of more than 5, contact a HWM representative for advice.

Repeat the process for the second pressure transducer. This is identical but requires selection of the "PRV Outlet pressure" transducer by picking "Channel 2" on the drop-down control.

To verify the transducers are re-zeroed, whilst still in atmospheric conditions:

Select the PRV Installation tab and click on the "Live values" button.

The Upstream and Downstream pressure values should now read zero, or very close to zero.

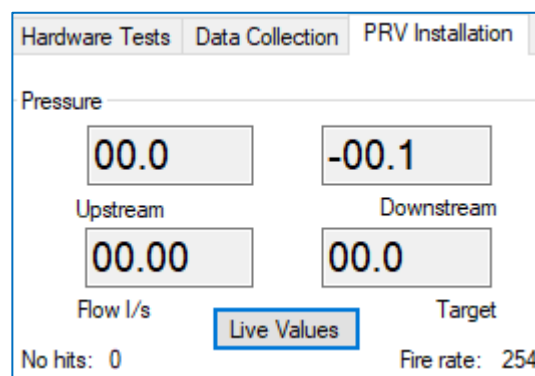

... Click the "Stop" button to end the verification.

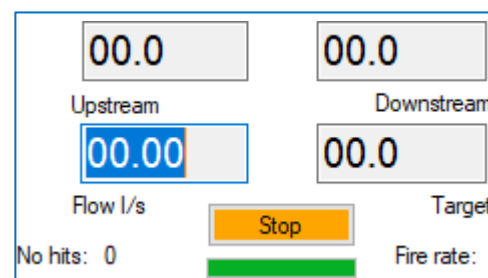

## 4.6 PREPARE THE PIPEWORK FOR THE SENTINEL 2

Accessory kits which include colored hoses are available from HWM (ACT00\* series accessory kits); Colored hoses makes identification easier. A manual 3-way valve and quick-connect fittings are also available. The standard ACT002/STD kit is shown below:



Use the installation diagrams to select the type of installation required:

- Standard installation where inlet pressure to PRV is **less than 90m**.  
(Refer to diagram in section 3.2.1 for use with internal pressure transducers).  
(Refer to diagram in section 3.2.2 for use with external pressure transducers).
- Standard installation where inlet pressure to PRV is **more than 90m**.  
(Refer to diagram in section 3.2.3 for use with internal pressure transducers).  
(Refer to diagram in section 3.2.4 for use with external pressure transducers).

Refer to the relevant diagram and cut the colored pipe to the required lengths.

## 4.7 PREPARE THE PRV FOR SENTINEL WATER FEED / PRESSURE TRANSDUCERS

The PRV valve should be fitted with service taps that allow maintenance whilst the PRV is in operation.

An example is shown opposite.

Choose locations to be used for attaching any Sentinel pressure transducers and also the water feed to the Hydroswitch inlet port.

Ensure these service taps are closed to allow work to proceed.

Fit Y-adaptors or quick-release connectors to the PRV, as required, to allow connection to Sentinel 2 at a later stage.

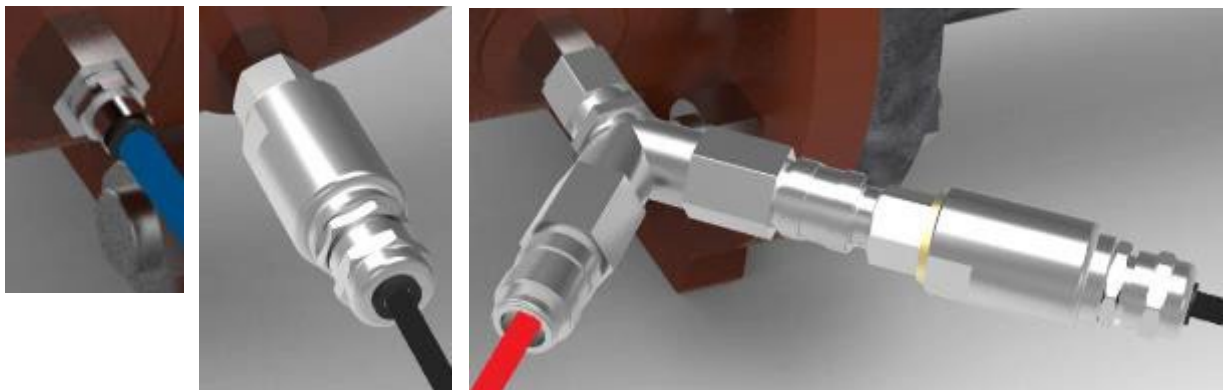
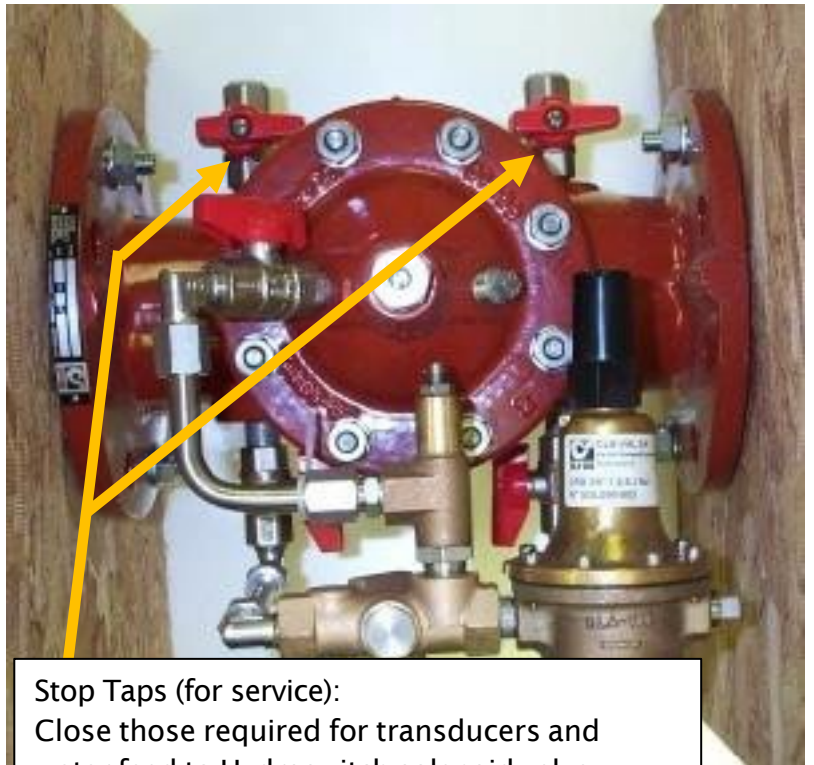

Do not fit any hoses or pressure transducers to the PRV at this stage.



## 4.8 CONNECT SENTINEL SIDE PIPEWORK

The pipes will be sealed and retained by the connector (until they are manually released, which requires pushing on the connector's ring whilst pulling the pipe away from the connector).

Where the Control box has internal pressure transducers, a quick-release adaptor is required to be fitted to the pipe-end before it can be attached.

Pipes can be connected to the adaptors by pushing the end of the pipe into the port.

The pipes will be sealed and retained by the connector (until they are manually released, which requires pushing on the connector's ring whilst pulling the pipe away from the connector).

Fit the adaptors to the end of the pipes (as required) and attach to the Control box.



Fit any T or Y adaptors that may be required.



Attach all 3 the pipe ends to the manual 3-port valve.

Attach the pipes to the 3-way valve, but do not yet attach the pipe to the actuator.

Make sure the 3-way handle is pointing to the green control pipe (shown).

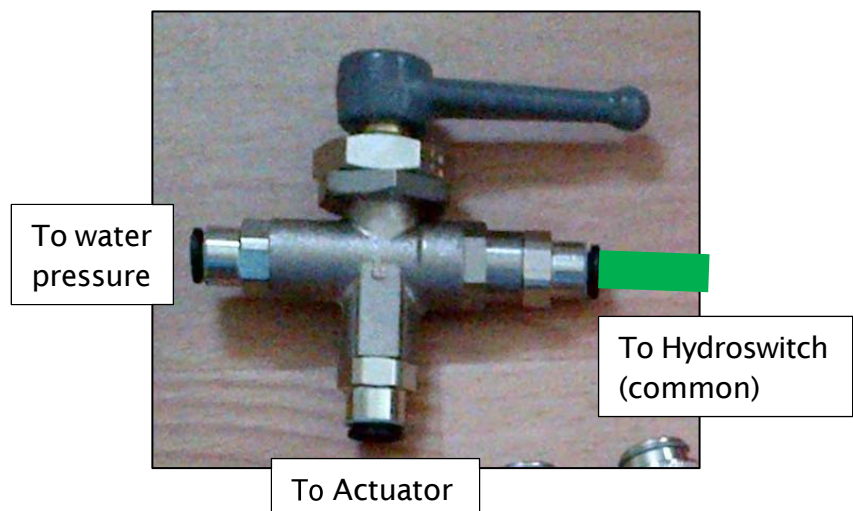

Fit adaptors as required to the 3-way valve of Hydroswitch.

Attach water pressure hose to the port shown as "Pressure Feed" in the diagram opposite.

Attach a water hose to the port shown as "Vent" in the diagram opposite, and route to a suitable drainage point.

Attach the water hose from the 3-way manual valve to the port shown as "Actuator (normally via a manual tap)" in the diagram opposite.

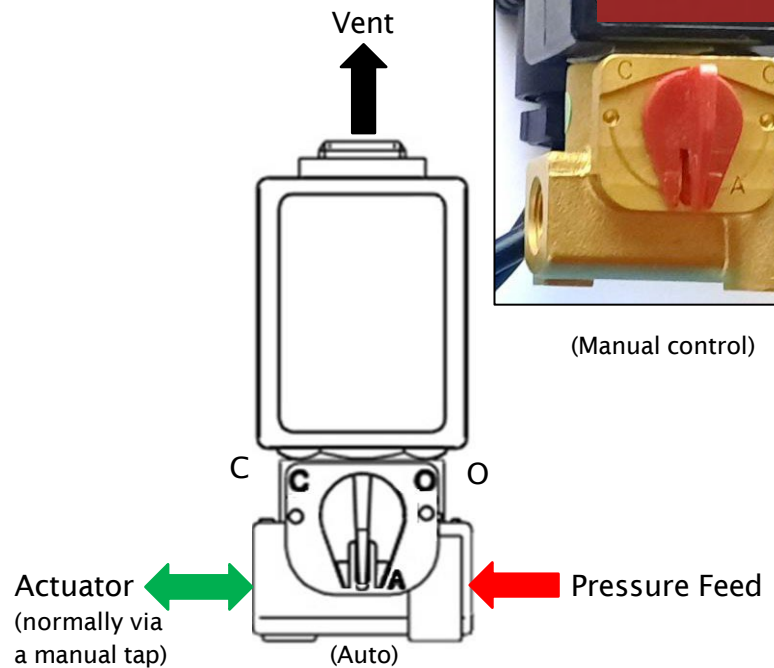

#### 4.9 SET HYDROSWITCH VALVE INTO AUTO MODE

A manual override control is on the Hydroswitch valve.

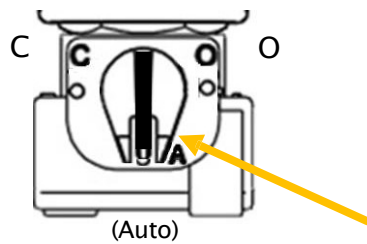

Set manual control to "A" (Auto).  
(Required for normal operation).

To change from "O" to "A", the manual override must be turned from "O" to "C" and then to "A" : " O → C → A".



#### 4.10 CONNECT TRANSDUCERS AND CONTROL PIPEWORK ON PRV SIDE

Before proceeding, confirm that any pressure transducers are of a suitable pressure range, that the channels have been set up, and the transducers have been re-zeroed at atmospheric pressure.

Connect any **external** pressure transducers to the appropriate location on the PRV valve, ensuring that:

- The upstream side is connected to the “PRV Inlet Pressure” connector.
- The downstream side is connected to the “PRV Outlet Pressure” connector.

Connect any **internal** pressure transducers by attaching the pipe quick-release connector to the appropriate location on the PRV valve.

- Ensure the upstream side is connected to the “PRV Inlet Pressure” transducer.
- Ensure the downstream side is connected to the “PRV Outlet Pressure” transducer.

If not already attached, connect the water feed to the Hydroswitch.

The water feed should come from the inlet side of the PRV if the pressure is below 90m; otherwise, the water feed should come from the outlet side of the PRV (which has a reduced pressure).

**Caution:** Move the manual 3-way valve into the middle position (all ports are sealed).  
Do not attempt to pressurize or bleed the connected plumbing at this stage or high pressure water could be released from open pipe-ends.

#### 4.11 PREPARING TO FIT THE ACTUATOR

Note: The following instructions assume that the valve is neither vented to the maximum (fully open), nor used to cut the water supply (fully closed) but is under the control of the fitted pilot valve.

It also assumes that the PRV is fitted with service stop-taps at the relevant ports on the valve, allowing the components surrounding the main valve to be serviced.

Ensure that the PRV is working properly before proceeding.

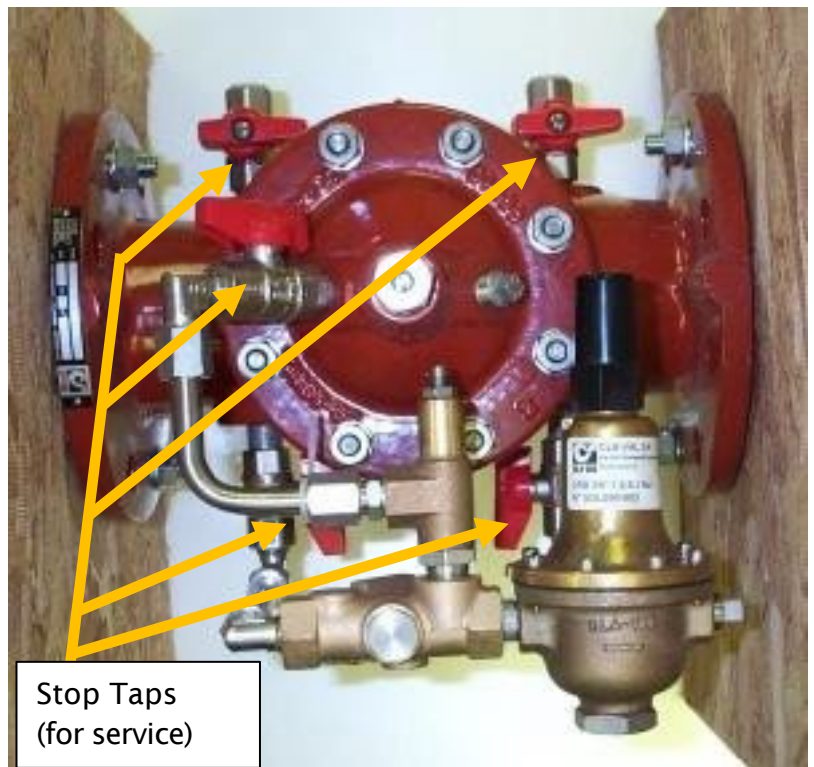

Lock the PRV top chamber by closing the valve to the top chamber, if possible.

If your PRV has taps on the pipe rail, shut both the input and output path of the pilot valve together (at the same time).

This will ensure that the volume of water contained in the pilot valve will remain constant; its diaphragm is locked in position.

Close PRV top chamber valve

Simultaneously close the input and output path to the pilot valve

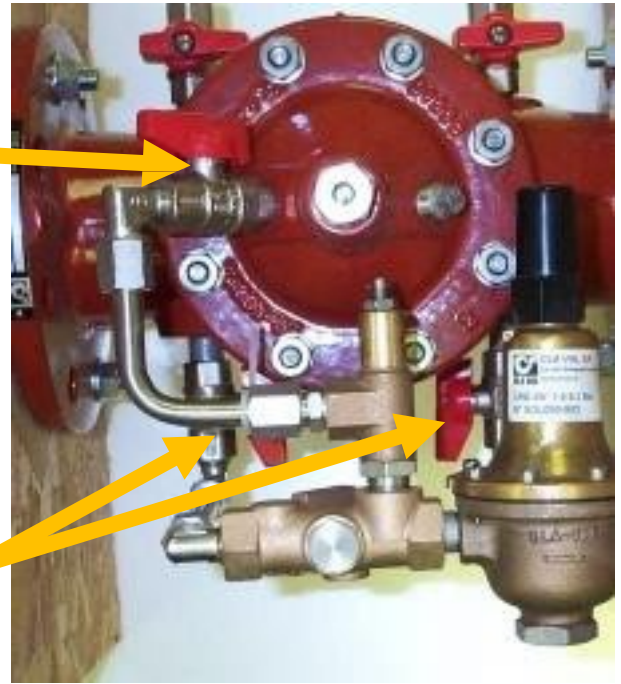

Note: The upper chamber of the PRV valve is now locked in position. The output pressure is not regulated, and any variations in inlet pressure will affect the output pressure

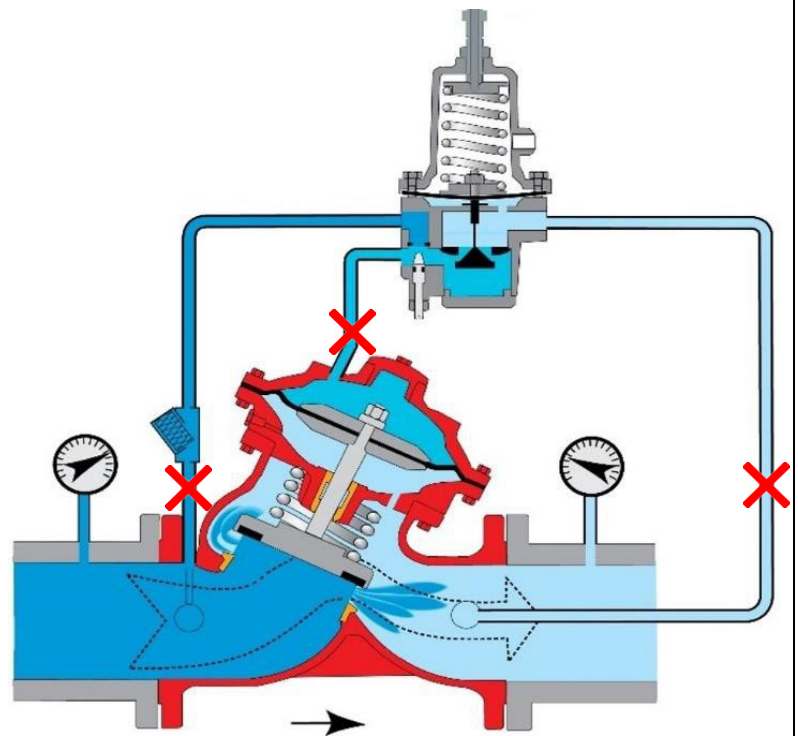

## 4.12 FITTING AND ADJUSTING THE HWM MECHANICAL ACTUATOR

Ensure that the thread of the HWM mechanical actuator being used is the same type of thread as the existing adjustment bolt on the PRV pilot valve. (HWM can supply alternative threads if the actuator is unsuitable).

Screw the top nut and bottom nut towards the middle nut so that they are together (see picture).

Screw the actuator thread into the actuator head until it is finger tight. (Use the middle nut).

This moves the plunger to the top of the inside of the actuator upper chamber. The pin (lower part of the plunger) should now be fixed.

Note the depth into the pilot valve of the existing bolt. Also note the force required to turn it at that position.

Unscrew and remove the existing PRV pilot adjustment bolt. (see picture). Check the outlet pressure reading whilst removing the bolt; the pressure should not change. If pressure drops at this point a valve is leaking.

Note: Use a pressure gauge on the PRV outlet side.

Screw the HWM mechanical actuator into the pilot of the PRV.

It should be positioned at approximately the same depth as the pilot bolt, which has just been removed.

Rotate the actuator to apply the same force that was applied by the (now removed) adjustment bolt.

Open both the input and output path of the pilot valve together (at the same time, if closed).

This will permit water to flow through the pilot valve; its diaphragm is no longer hydraulically locked in position.

Slowly open the PRV top chamber valve. The PRV will now return to pilot control, influenced by the actuator pin position.

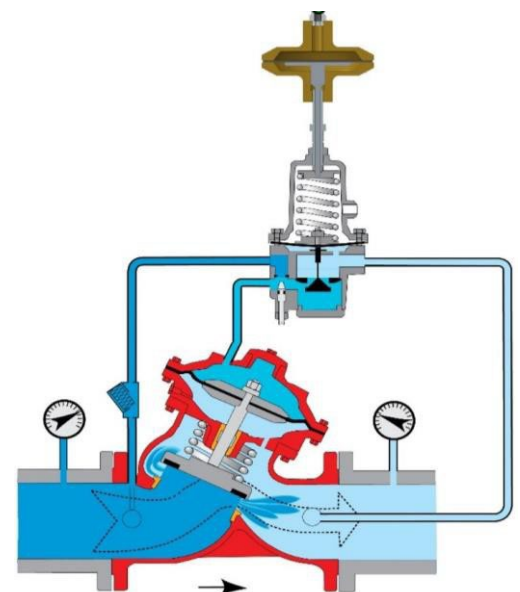
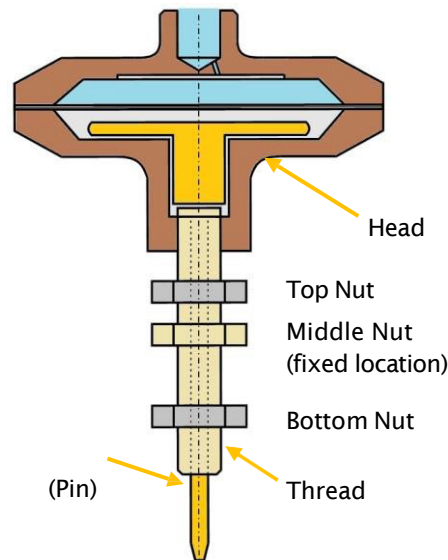

Whilst checking the outlet pressure of the PRV, **set the maximum pressure** required by adjusting the position of the **actuator bolt**.

To do this, use the middle nut (fixed) on the actuator thread:

- Screw it clockwise / inwards to increase the output pressure.
- Screw it anticlockwise / outwards to decrease the output pressure.

The adjustment should be made slowly to avoid damage that could be caused by sudden changes to the water network pressure. Make sure you allow time for the PRV to settle its pressure after adjustment. Once the maximum pressure is achieved, tighten the bottom lock-nut on the actuator screw thread against the PRV pilot (see picture).



**This will secure the maximum outlet pressure.**

Whilst checking the outlet pressure of the PRV, **set the minimum pressure** required by adjusting the position of the **actuator head**.

To do this, hold the middle nut (fixed) on the actuator thread stationary, using a spanner, whilst rotating the actuator head.

- Screw it anticlockwise / outwards to decrease the output pressure.
- Screw it clockwise / inwards to increase the output pressure.

The adjustment should be made slowly to avoid damage that could be caused by sudden changes to the water network pressure. Make sure you allow time for the PRV to settle its pressure after adjustment. Once the minimum pressure is achieved, tighten the top lock-nut on the actuator screw thread against the underside of the actuator head (see picture).

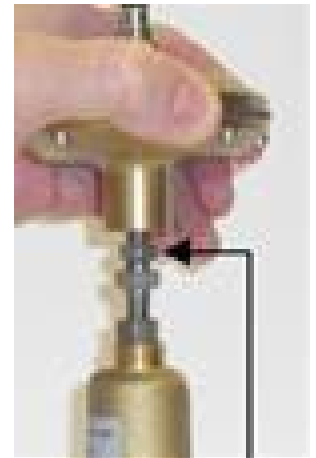

**This will secure the minimum outlet pressure.**

Insert the green pipe (which connects the 3-way manual valve) into the top of the actuator head (as shown).

The Sentinel actuator is now installed.

The current state of the system is that the actuator is holding the PRV pilot at the Minimum outlet pressure. The actuator chamber and Sentinel pipework are empty of water.

The 3-way tap is in the central (closed) position.

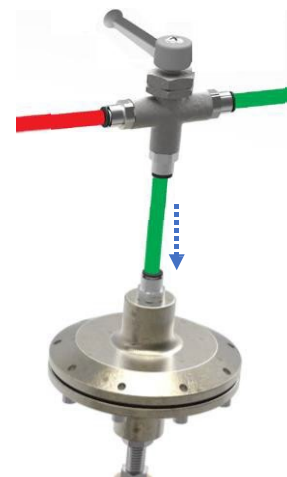

#### 4.13 BLEED AIR FROM THE PIPEWORK AND ACTUATOR

Open the PRV service valve that provides the water supply to the Hydroswitch.

Open any additional PRV service valve that connects water pressure to any pressure transducers (internal or external).

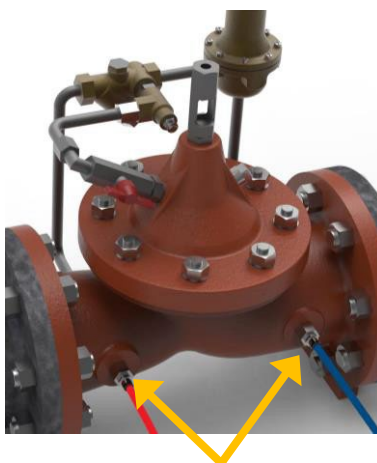

Open service valve that provides Hydroswitch water feed and any that connect to internal transducers.



Open service valve that provides Hydroswitch water feed and any that connect to external transducers.

Where internal transducers are fitted, detach and then re-attach the pipes using the quick-release connectors at the Sentinel 2 side (several times). This will allow air to escape from the pipes via the quick-release connector and be replaced by water.

**Caution:** Check the **needle valve** is set to limit the PRV pressure changes when the actuator switches between low and high.



Set the Sentinel to Override to a target pressure of Low for a suitably long duration (e.g. 30 mins). This will open the path between the 3-way tap and vent.

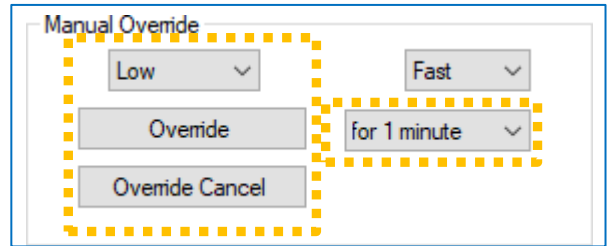

Change the position of the 3-way tap, allowing water to enter the red pipe from the PRV service valve. Air and water should escape into the actuator and its pipework. Move the tap to face the green pipe to allow water to escape towards the vent pipe. Repeat as necessary to bleed most of the air from the actuator.

Finally leave the tap in a position which connects the solenoid valve pipe through to the actuator.

Use the Manual Override controls within the PRV Installation tab of IDT to bleed air out of the pipework:

Cycle between a target pressure of High and Low (several times) to allow air to bleed from the pipework.

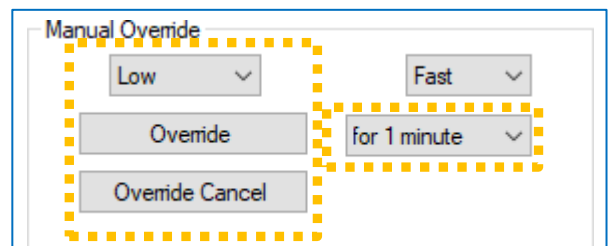

#### 4.14 TEST PRESSURE TRANSDUCERS

If pressure transducers are fitted, select the PRV Installation tab of IDT.

Click on the “Live Values” button.

The display will show readings for any fitted transducers. E.g.:

- Upstream Pressure (in meters)
- Downstream Pressure (in meters)
- Flow (in l/s)

Confirm the values are as expected.

Click the button once more to stop displaying the readings.

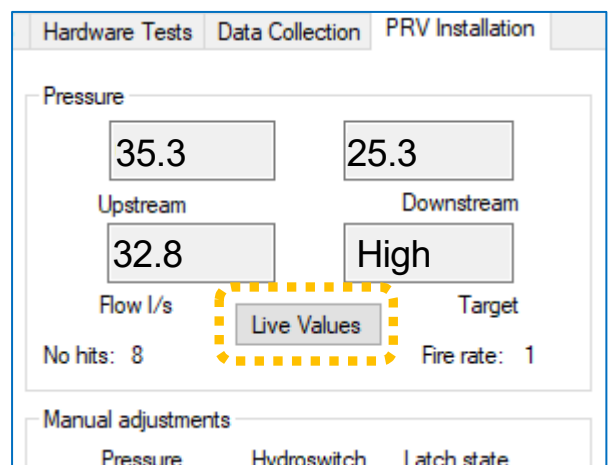

## 4.15 TESTING THE ACTUATOR AND PRV PRESSURE CHANGE RESPONSE

Ensure the PRV controller is activated.  
(Click on the Start Control button if it is not already green).

The PRV response to actuator changes should be tested by switching between Low and High pressures several times to ensure it is operating correctly and that the time the PRV takes to respond is suitable for the water network.

It is important that the pressure does not change too quickly to prevent damage to the PRV, pipe network, or downstream equipment and users (e.g., sudden water pressure surges and dips, water-hammer, or any other effects).

**Adjust the needle valve** within the pilot control to give the required response time and also ensure a smooth pressure transition when switching.

This can be achieved by setting a target pressure (High or Low) within the Manual Over-ride section, selecting the override time period for testing, and then clicking on the Override button. The system should gradually change to either the High or Low pressure settings and then stabilize.

The pressure can be verified using an external pressure meter or by using the Sentinel 2 pressure transducers with IDT.

To use the Sentinel 2 transducers, click the “Live Values” button. The display will update to show pressure and flow values. (Other buttons are disabled whilst this is operating; click on the “Stop” button to re-enable the other button controls).

The screenshot displays the 'PRV Installation' control interface. At the top, there are tabs for 'Setup', 'Hardware Tests', 'Data Collection', and 'PRV Installation'. The main area is divided into three sections:

- Pressure:** Shows 'Upstream' pressure at 00.0 and 'Downstream' pressure at 00.0. Below these are 'Flow l/s' at 00.00 and a 'Target' set to 'High'. There are also 'No hits:' and 'Fire rate:' indicators, and a 'Live Values' button.
- Manual adjustments:** Includes 'Hydroswitch' and 'Latch state' options, with buttons for 'PRV A' and 'PRV B'.
- Manual Override:** A dashed yellow box highlights this section, which contains a 'Low' dropdown menu, an 'Override' button, an 'Override Cancel' button, a 'Fast' dropdown menu, and a 'for 1 minute' dropdown menu.

At the bottom of the interface, there are two buttons: 'No Control' and 'Start control' (which is highlighted in green).



## 4.16 PRV CONTROL METHOD AND SETTINGS

Sentinel2 provides 2-point pressure control; It is used to switch the output pressure for the PRV between either a High or Low pressure setting, with the needle valve of the pilot controlling the gradual downstream pressure changes between any transition in the target pressure.

The target pressure (either High and Low) is set in Sentinel2 using a pressure profile table, of which two types exist: Time control and Flow control.

An area within the Control Settings defines which pressure profile tables will be used.

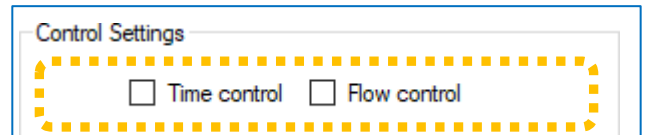

The installer should enable one or both of the settings, as required.

Note: If neither of the control settings are enabled the unit behaves as if PRV control is disabled; the PRV actuator setting remains fixed.

### 4.16.1 Setup of pressure control using a Time profile

To use a pressure profile that is based on time, tick the “Time control” option.

(With the “Flow Control” box un-ticked, flow does not participate in control decisions, but is still logged).

... A “Safety Override” panel appears when time control is exclusively selected. (See section 4.16.2)

... A “Time Control” table will also appear.

Currently (in the illustration), the table is blank; there are no entries visible.

To enter a line into the table, click on the “+” button.

... A new line is added, which can be edited with the required settings. (The table has a capacity of up to 32 lines).

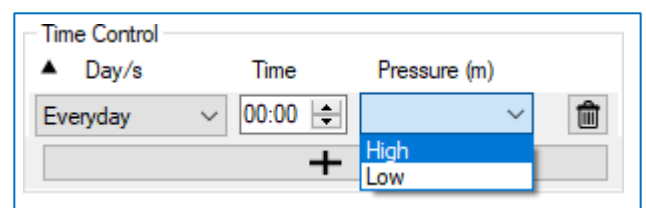
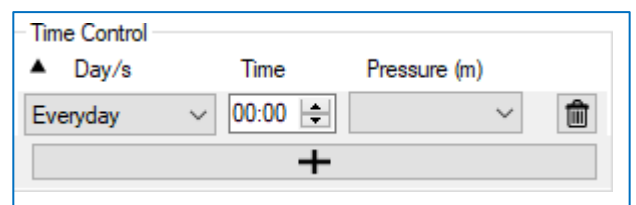
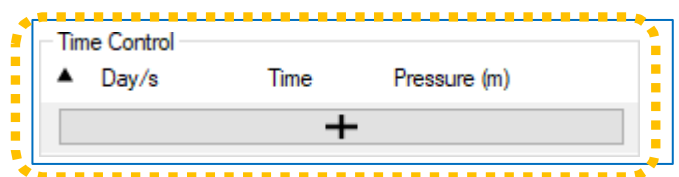
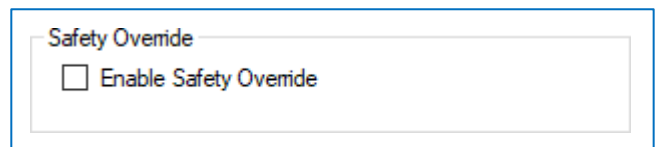
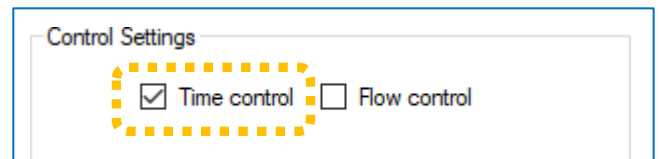

The Time Control pressure profile can be built as a table of days, times, and a choice of the High or Low setting.

Each line requires a start time, and a selection of which day / set of days the setting will be relevant to.

The day selections can be mixed.

To enter a time, select either the hours or minutes digits and over-write them with your settings.

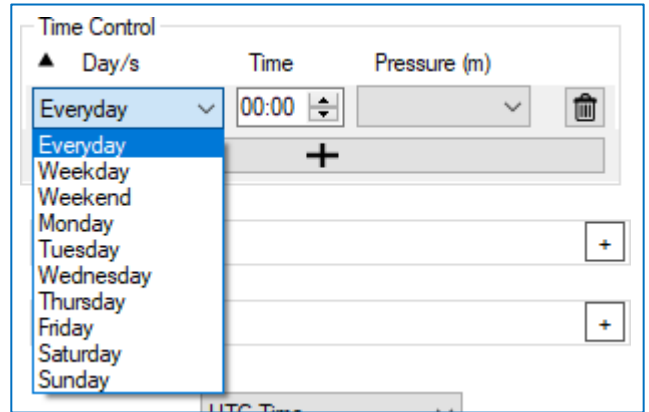

The Time Control profile of Sentinel 2 causes a switch-over of the actuator to the new setting when reaching an entered time.

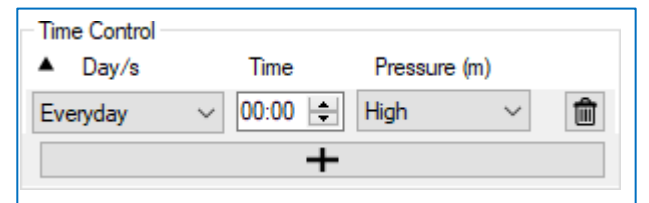

Lines can be added to IDT in any order. After the program has been saved to the device and read back, the profile can be checked; the lines will be re-sequenced according to time of change.

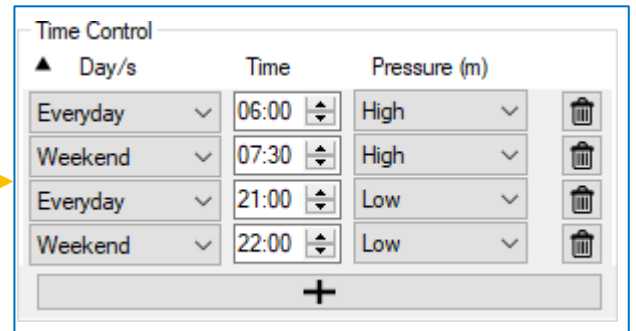
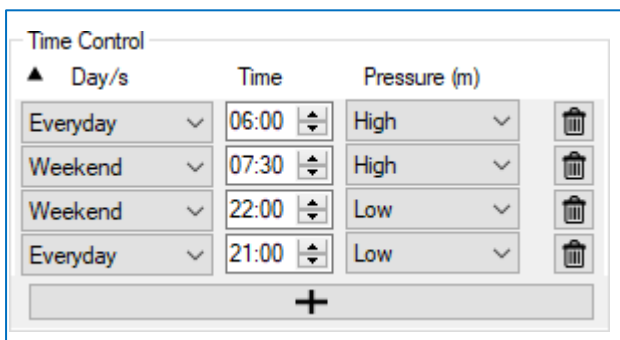

Confirm the settings match your expectations. e.g. With the above settings, an additional line is required to ensure the weekend pressure remains High at 21:00.

A more specific setting made in the Day selection will over-ride a more general setting.

e.g.

- “Saturday” will over-ride “Weekend” and “Everyday”.
- “Weekend will over-ride “Everyday”.

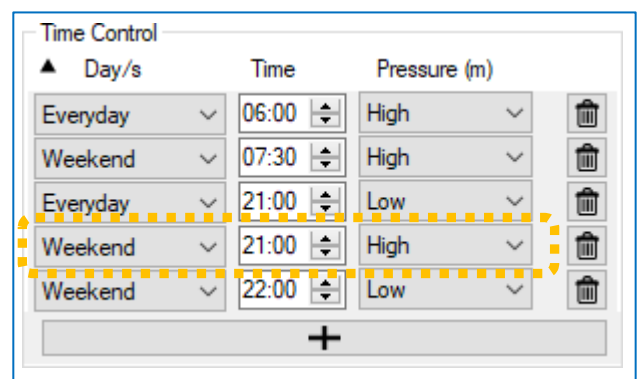

#### 4.16.2 Setup of a (pressure) Safety Override for Time Control

When time control is exclusively selected, a Safety Override control is made available.

To use this feature, a Sentinel2 model with a pressure transducer for monitoring the downstream pressure is required to be installed.

The control can be disabled or enabled.

When enabled fill in the threshold settings and required action.

e.g., With the settings shown above, the system may have been set up with a Low PRV pressure mechanically set to 25m. If the pressure downstream of the PRV falls below 20m for a period of more than 10 minutes the actuator will override to the High Pressure setting.

Example uses:

- If a fire hydrant is used whilst pressure is set to Low, the pressure may drop due to demand. Therefore, over-ride to High pressure.
- If a water mains burst occurs whilst pressure is set to High, the pressure may drop due to water loss. Therefore, over-ride to Low pressure.

The screenshot shows a 'Safety Override' configuration panel. It includes a checked checkbox for 'Enable Safety Override'. Below this are two input fields: 'Downstream pressure low threshold (m)' with the value '20' and 'Time elapsed before activation (mins)' with the value '10'. At the bottom, there is a dropdown menu currently set to 'Override to High Pressure'.

#### 4.16.3 Setup of pressure control using a Flow profile

To use a pressure profile that is based on Flow, tick the “Flow control” option.

To use this feature, the Sentinel2 digital flow interface (meter pulse collection) is required to be connected to the meter-pulse output of a meter within the downstream side, close to the PRV.

... A “Flow Control Settings” panel will appear with additional options to set.

... and a “Flow Control” panel will be appear.

The screenshot displays three stacked configuration panels. The top panel, 'Control Settings', has 'Time control' unchecked and 'Flow control' checked. The middle panel, 'Flow Control Settings', includes a 'Default Pressure' dropdown set to 'High', a 'No Flow Timeout (mins)' field with '15', a 'Sample rate' field with '00:00 10' and an 'Ave' field with '6', and a 'Flow Cal' field with '1'. The bottom panel, 'Flow Control', shows 'Low Flow l/s' set to '972.00' and 'High Flow l/s' set to '2988.00'. A dashed yellow box highlights the 'Flow control' checkbox and the 'Flow Control Settings' and 'Flow Control' panels.

The general concept of Flow control is that Sentinel periodically makes an evaluation of the recent water demand to the downstream network and decides whether a High or

Low pressure target is appropriate. It will then set the actuator to the required target pressure.

The lower part of the Flow Control Settings panel deal with data collection for making the evaluation.

The “Sample Rate” determines how often a flow measurement sample is taken for evaluation, *for PRV controller purposes only*.

Some statistical function (average) is applied to smooth out any fluctuation in the measurements which could cause rapid and chaotic changes to the target pressure. Typically, the system samples every 10 seconds and uses the average from the last 6 measurements to arrive at a target pressure.

(“Flow Cal” in the above picture is a repeat of the calibration setting of the Flow channel. e.g. Units per pulse, for a flow pulse counter interface. It does not require adjustment).

Flow Control Settings

Default Pressure	High	
No Flow Timeout (mins)		15
Sample rate	00:00 10	Ave 6
Flow Cal		1

Since the pressure profile is dependent on Flow, certain settings in Sentinel 2 define what should happen if there is a fault detected in the Flow meter:

The target pressure will be as per the setting “Default Pressure”.

One condition that can register as a flow-sensor fault is when there are no flow pulses detected for a time period. This condition must exist for the time set in the “No Flow Timeout (mins)” field before it is recognized as a fault.

(No specific alarm is generated for this condition, but it is included in the messages delivered to the server during normal call-in).

Flow Control Settings

Default Pressure	High	
No Flow Timeout (mins)		15
Sample rate	00:00 10	Ave 6
Flow Cal		1

The “table” for 2-point flow control consists of just 2 values. These are the thresholds for making the switch:

- From High to Low pressure output (“Low Flow l/s” setting), and
- From Low to High pressure output (“High Flow l/s” setting)

Flow Control

Low Flow l/s	972.00
High Flow l/s	2988.00

The most common use scenario for these settings is to reduce the PRV output pressure during times of low water demand, such as during the night. Conversely, the PRV should be switched to a higher output pressure when water demand increases, such as during the day.

There should be some strategy employed to prevent the PRV being driven into making chaotic (frequent) pressure changes:

- Make a careful consideration as to the difference should exist between the Low and High thresholds, (this is commonly known as “hysteresis”).  
Between the two thresholds there will be no change; crossing a threshold is required to initiate a change.  
If the Low Flow and High Flow settings are too close, frequent pressure changes could occur when the network flow is hovering around these values.
- Use the “Ave” setting to smooth out any over-reactiveness (increasing the value can delay any target pressure changes until water demand has consistently changed).

e.g. With the settings shown (above), pressure will be High when it increases past 2988 l/s and will change to Low when it falls below 972 l/s.

IDT will detect an error situation for certain situations, such as trying to program unworkable settings within the unit.

The installer is responsible for choosing suitable values, based on both the network characteristics and the desired behavior of the PRV.

(IDT does not give any warning if the installer has chosen inappropriate values for the characteristics of the network).

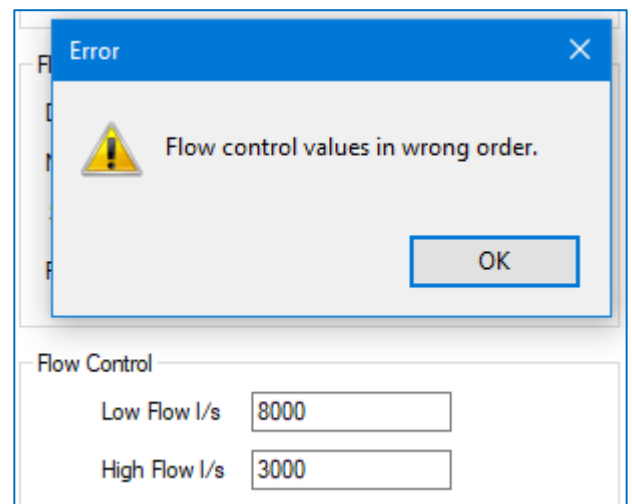

**WARNING:** This equipment should be installed, adjusted, and serviced by qualified water industry maintenance personnel familiar with the construction and operation of the equipment and the hazards involved. Failure to observe this precaution could result in damage to the water network.

#### 4.16.4 Setup of pressure control using a combined Time and Flow profile

To use a pressure profile that is based on both time and Flow, tick both the “Time control” and “Flow control” options.

... An additional choice becomes visible, which is required to be set.

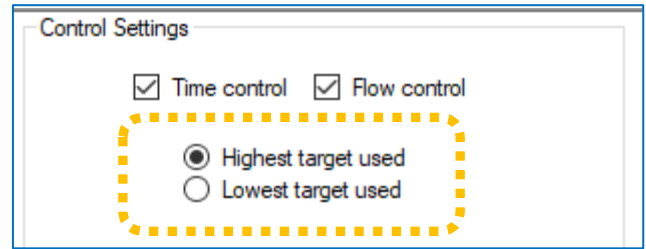

With both options enabled, the controller has to evaluate both control methods in order to determine the target setting.

- It calculates a pair of candidate settings (one from each control method).
- The chosen option then determines whether the controller selects the highest or lowest of the candidate settings (if there happens to be a difference).

#### 4.17 SETUP FOR ANNUAL TIME ADJUSTMENTS

Some countries have a scheme for adjusting the local time annually to make the most of available sunlight hours and for safety reasons.

(e.g. British Summer Time, Daylight saving).

Since water usage patterns follow people’s behavior to some extent, it is possible for Sentinel to be programmed to adjust its local clock to match the scheme and thereby temporarily adjust effectivity times for any time-related pressure profile.

The dates of “DST start” and “DST end” (Daylight Saving Time start / end) can be found within the Settings tab, along with a choice of the adjustment time offset within the start and end dates.

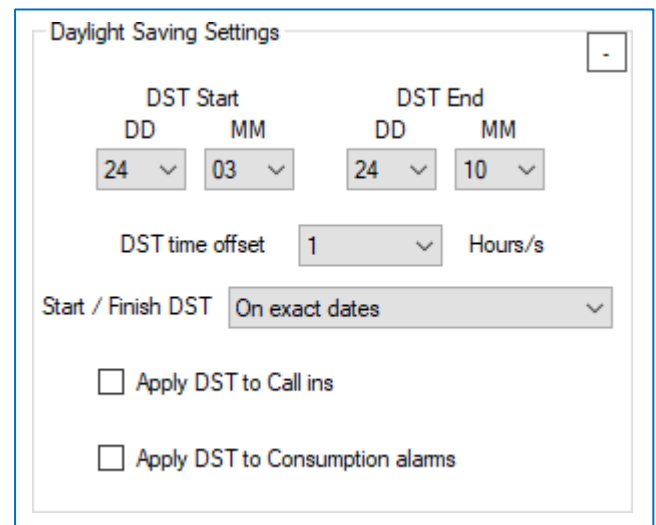

To disable the adjustment, set the DST time offset to 0 hours.

## 4.18 SAVE PROGRAM / ACTIVATING SENTINEL PRV CONTROL

For Sentinel to be able to control the PRV using the current program settings (held by the IDT program), IDT must send the settings to the unit, which must then store it.

Click on the “Setup Device” button, found by selecting the “setup” tab and scrolling to the bottom.

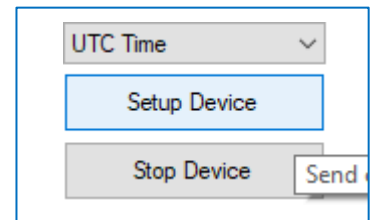

The process will proceed as described earlier in section 2.3.4. However, the installer must now ensure that Sentinel is fully activated.

i.e. Click on “Yes” when asked if you wish to start controlling now.

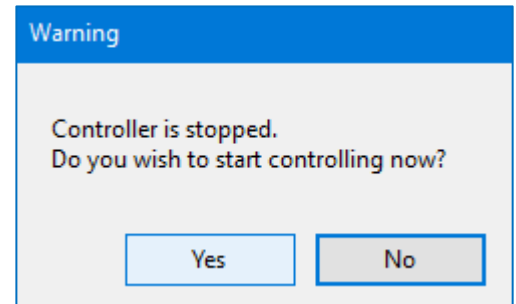

Note: After the unit is fully operational, the user can still pause control and (later) restart it without making any further program changes. This can be done by using the buttons within the PRV Installation tab...

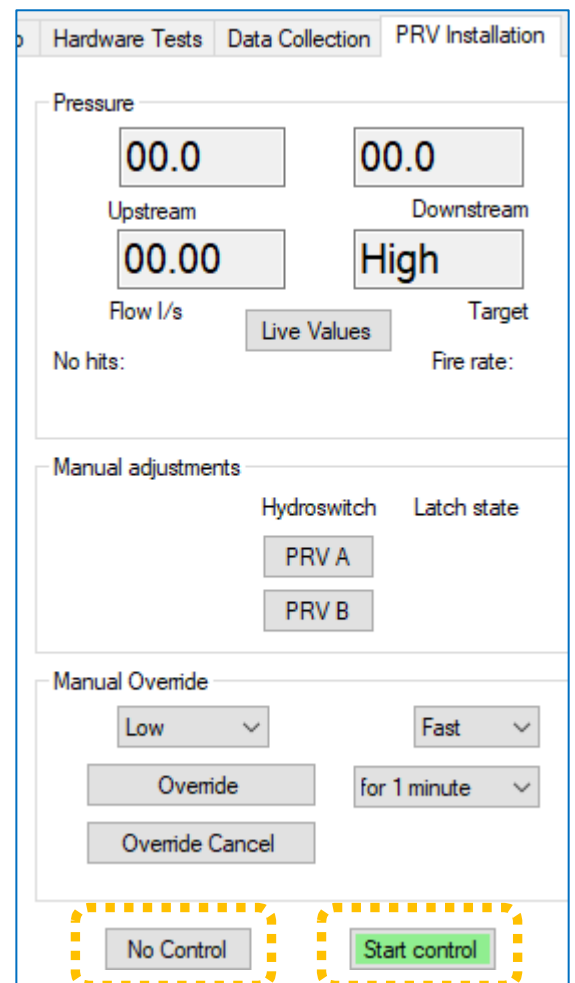

Click on the “No Control” button if you wish to pause automatic PRV control.

Click on the “Start control” button if you wish to un-pause automatic PRV control.

**Caution:** Be sure to un-pause the control before leaving the unit.



## 4.19 SETTING LOGGER STARTUP / MEASUREMENT SAMPLE RATES

The “Logging Parameters” panel shows timing parameters for the logger functions within Sentinel 2.

For Sentinel 2, the built-in logger should be set for the measurement interfaces to be logged frequently. Therefore, set to “Log data at specified time interval”.

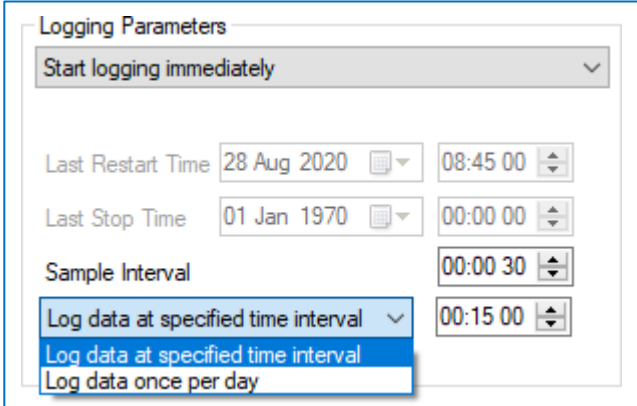

The “Sample Interval” is used to produce a set of data for the purpose of applying optional statistical functions (e.g. Average).

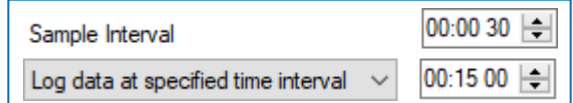

The “Log ... interval” specified time is used to save a datapoint once any statistical functions have been applied to the latest set of measurements.

The settings shown here are typical for Sentinel operation.

## 4.20 SETUP OF DATA DELIVERY

Sentinel can be setup to call into the HWM DataGate server (over the mobile phone network) at specific times. During a call-in it will send measurement data or receive “remote programming commands”.

The installer should setup Sentinel2 with the required schedule.

Note: If more than two call are required per day, an external battery pack will be required. Without an external battery providing power, Sentinel2 will restrict itself to two calls per day, maximum.

Unsent data will be stored in the unit and will be sent at next call-in.

### 4.20.1 Call-in times (schedule and protocol)

IDT displays a table for the setting of the call-in pattern.

A selector on the first line determines if the unit will call-in at regular intervals (select a mode of “Freq”) or at specific times (select a mode of “Time”).

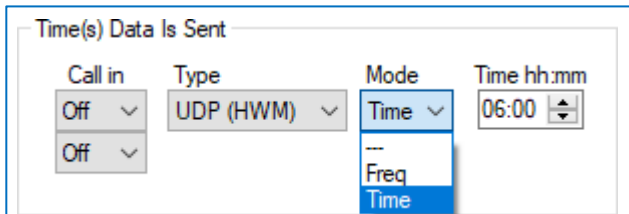

When Frequency is selected, it is not possible to add any additional lines to the table; just one exists.

The frequency is set by entering the required time interval between call-ins.

The screenshot shows a configuration window titled "Time(s) Data Is Sent". It contains four fields: "Call in" with a dropdown menu set to "On", "Type" with a dropdown menu set to "UDP (HWM)", "Mode" with a dropdown menu set to "Freq", and "Time hh:mm" with a spinner box set to "06:00".

When time is selected, additional lines will automatically be added if a line is enabled (by selecting "On") using the call-in control.

Set the time of the call-in at the end of the line.

Times can be "deleted" by selecting a line to "Off".

The screenshot shows a configuration window titled "Time(s) Data Is Sent". It contains four fields: "Call in" with a dropdown menu set to "Off", "Type" with a dropdown menu set to "UDP (HWM)", "Mode" with a dropdown menu set to "Time", and "Time hh:mm" with a spinner box set to "06:00".

Note: If no remote communication is required, set each 'Call in' drop box as 'Off'.

The protocol for sending in the data should also be selected. This should normally be UDP for correct operation of Sentinel2.

The screenshot shows a configuration window titled "Time(s) Data Is Sent". The "Type" dropdown menu is open, showing options: "UDP (HWM)", "SMS", "BRTU", and "HTTP". The "Call in" dropdown is set to "Off", "Mode" is set to "Time", and "Time hh:mm" is set to "06:00".

Note: The unit may be set to generate a message to the server, often called an alarm. These may be set to make calls in addition to any schedule programmed here.

#### 4.20.2 Destination

The unit needs to know details of the data destination so that it can send it to the correct server via the internet.

The installer can either put an internet address (IPv4) of the server in the "Address" field or use a URL.

In order to route the data to the server a UDP port-number is also required.

The server can also process messages sent via the SMS (text message) service.

The SMS number is the destination "mobile phone number" for SMS messages to reach the server.

The screenshot shows a configuration window titled "Data Destination". It contains several fields: "Address" with the value "inbound.hwmonline.com", "UDP Port" with the value "23024", and "SMS No." with the value "+447786200833". There is a checked checkbox for "Compress Data". Below that is a dropdown menu for "If logger has no data to send:" set to "Call in anyway". At the bottom, there are two unchecked checkboxes: "Alarms Sent via SMS Back-up" and "Secondary Files Sent via SMS back-up". There is also a dropdown menu for "Logger is Battery Powered".

Note: The settings and SMS number required for your company's server will be provided by your **system administrator**.

The remaining options in the “Data Destination” panel are related to potential power saving:

The setting for “Logger is Battery Powered” does not matter for Sentinel2; It automatically detects if an external battery is connected during its operation.

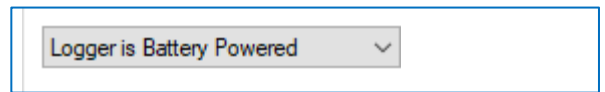

Data compression can be set to minimize length of messages and hence call times.

When Sentinel2 operates with DataGate / PressView it should always be set to “Call in anyway”; This allows remote programming of the device (although if logging has been set correctly, there should always be logged data to send).

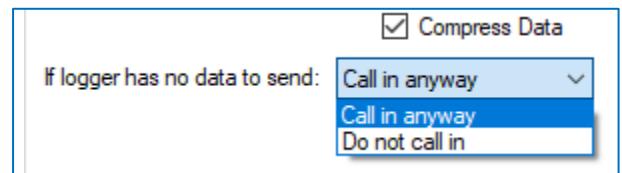

Primary data channels (as described in this user-guide) will fall back to being sent via SMS messages if the server cannot be reached by the mobile data network.

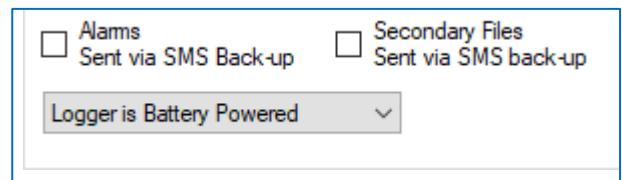

Tick the Alarms and Secondary Files (i.e. secondary data) if sending using the additional back-up method is also needed for these types of messages.

### 4.20.3 Setting Network access parameters

The unit needs to know how to connect to the internet using the mobile-phone data network. These details are set in the “APN settings”.

Either select the option to “Use GPRS test to choose APN settings” to allow automatic set-up ... or “Let me choose APN settings” to configure them manually.

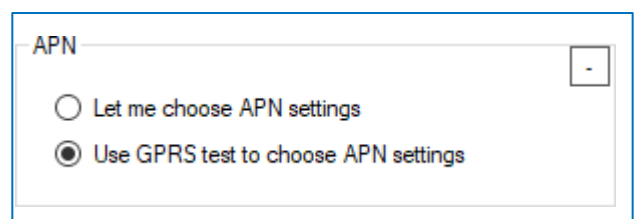

If the installer knows the type of SIM card fitted, the parameters may be selectable from one of the pre-sets known to IDT.

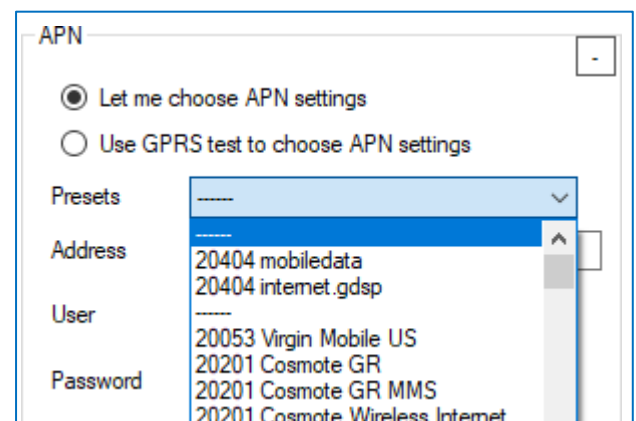

Alternatively, the user can enter the parameters for their fitted SIM card.

If the connection requires authentication, enter the username and password for gaining access to the network connection.

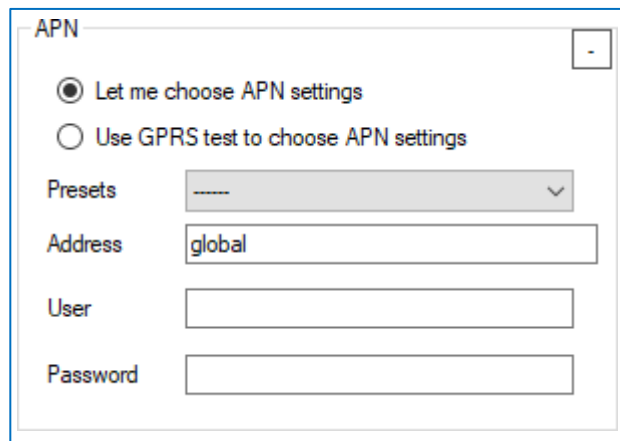

Note: The settings required will be provided by your **system administrator**.

#### 4.21 COMMUNICATIONS / ANTENNA LOCATION CHECK.

Communications over the cellular network can be confirmed by making a test call.

Click on the “Call Test” button, located at the bottom of the IDT program window.

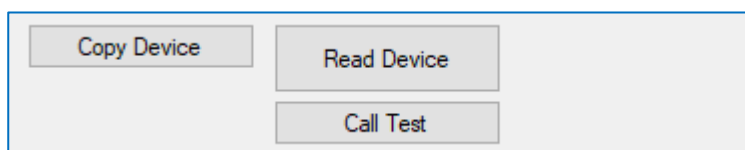

The call test will proceed.

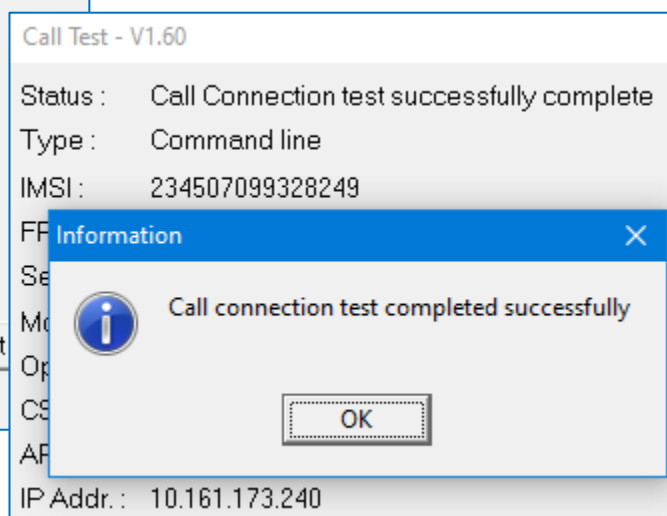
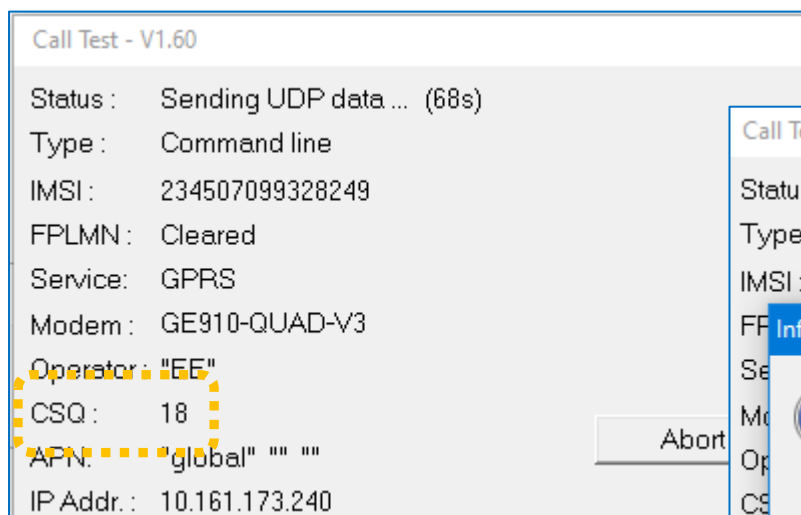

Confirm that a “Call connection test successfully complete” information box appears.

Note the parameter “CSQ”; this is an important indication of the signal strength with the antenna in the current position.

The best location for the antenna must now be found by comparing the CSQ value at various alternative locations.

Select the “Hardware tests” tab.

Then click on the “Modem” button.

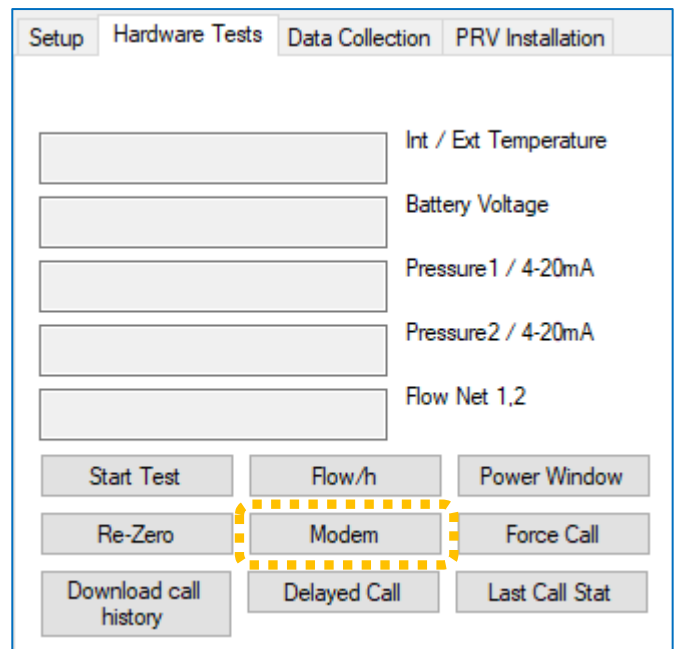

The modem is the cellular communications module built into Sentinel 2.

A new window will open with various types of modem tests.

Click on the “CSQ” button.

This measures the received signal strength, and a new measurement is made every few seconds.

CSQ values are in the range of 1 to 33. A higher number is better. We recommend a CSQ value of greater than 7 within the chamber, with lids closed, to facilitate reliable communication.

Move the antenna to various alternative locations to find the most suitable position. Stand well back from the antenna whilst the measurement is being made to ensure you are not blocking the signal.

To stop the test, click the CSQ button once more.

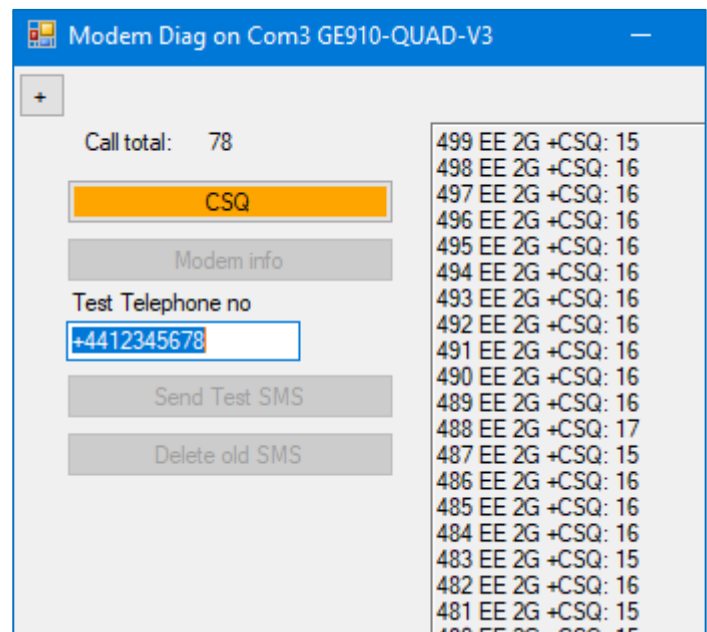

To check the sim card and modem are working, enter your mobile phone number into the 'Test Telephone no' box in international format as shown opposite.

Click the "Send Test SMS" button.

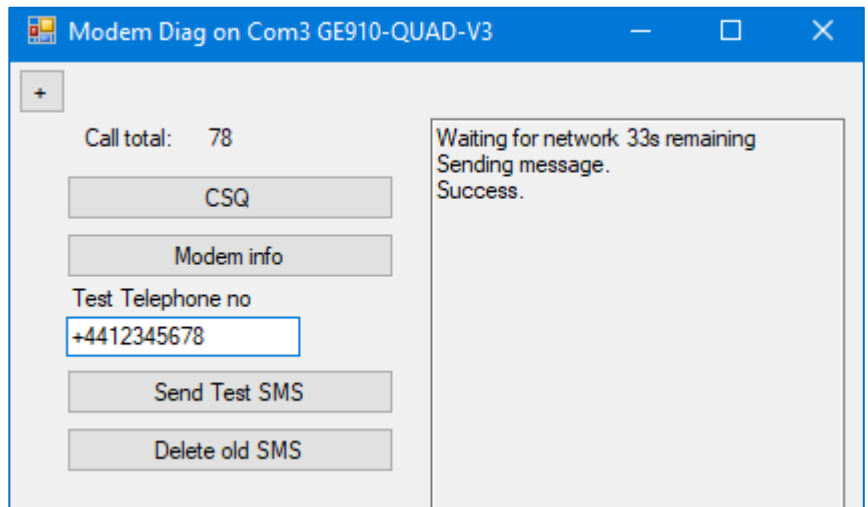

This will send a text to your phone confirming the phone number of the SIM and that calls can be made from the modem. If you fail to receive a text message this could indicate a sim or modem fault

#### **4.22 VERIFICATION OF THE CONFIGURATION.**

Ensure the program settings stored in IDT are transferred to the Sentinel; Click the Setup Device button, as described earlier.

It is recommended to check the settings in Sentinel to check the configuration has been correctly saved.

(i.e. Click the "Read device" button and confirm all settings are correct).

Check the status is also set to "Record".

Check the PRV controller Start control button is green.

#### **4.23 PROTECTION FROM FROST**

Where required, any tubing can be protected from frost with foam insulating pipe covers. These can be supplied upon request at additional cost or sourced locally from a hardware store.

To protect any required pressure transducers from frost, Sentinel 2 has the option of being supplied with external transducers, rather than internal transducers. This removes the possibility of the column of water within the pressure hoses connecting to the internal transducers of the controller from freezing and potentially becoming damaged, if left unprotected in harsh conditions.



## 5 GRAPHING / DATA DOWNLOAD AND PREVIEW

Measurements are saved by the Logger functionality built-into Sentinel. Measurements are normally incrementally uploaded to the DataGate server so that they can be:

- Viewed remotely.
- Optionally, be used by a user of the PressView system to fine-tune the performance of the Sentinel profile tables and settings.

Data can also be downloaded from the unit into IDT for previewing locally.

### 5.1 MANUAL DOWNLOAD OF DATA INTO IDT / PREVIEW AS A GRAPH

Select the “Data Collection” tab.

This initially shows only a set of controls.

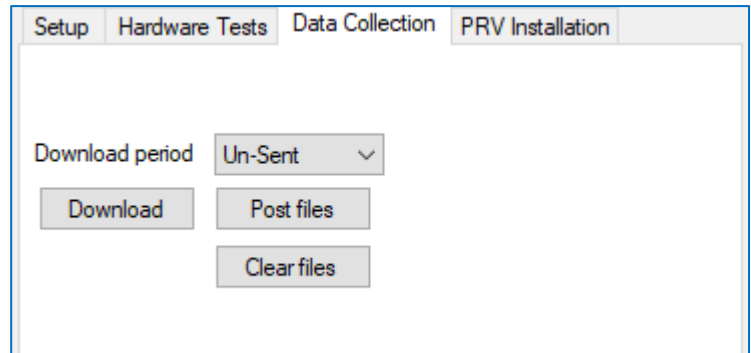

Choose a download period using the selector.

Then click on the “Download” button.

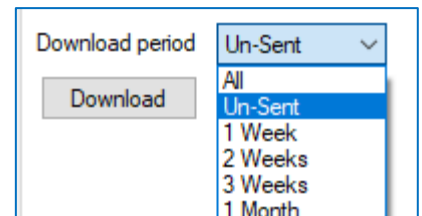

The data for the requested period will be downloaded into a file within the PC by the IDT program.

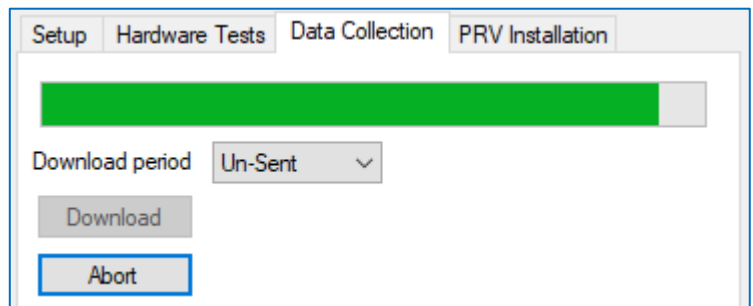

A graph will be displayed of the channels being logged.

To zoom to specific times/dates, click and drag over the part of the screen required.

Click the "Zoom Full" button to show all data once more.

A larger display can be shown by clicking the button shown opposite.

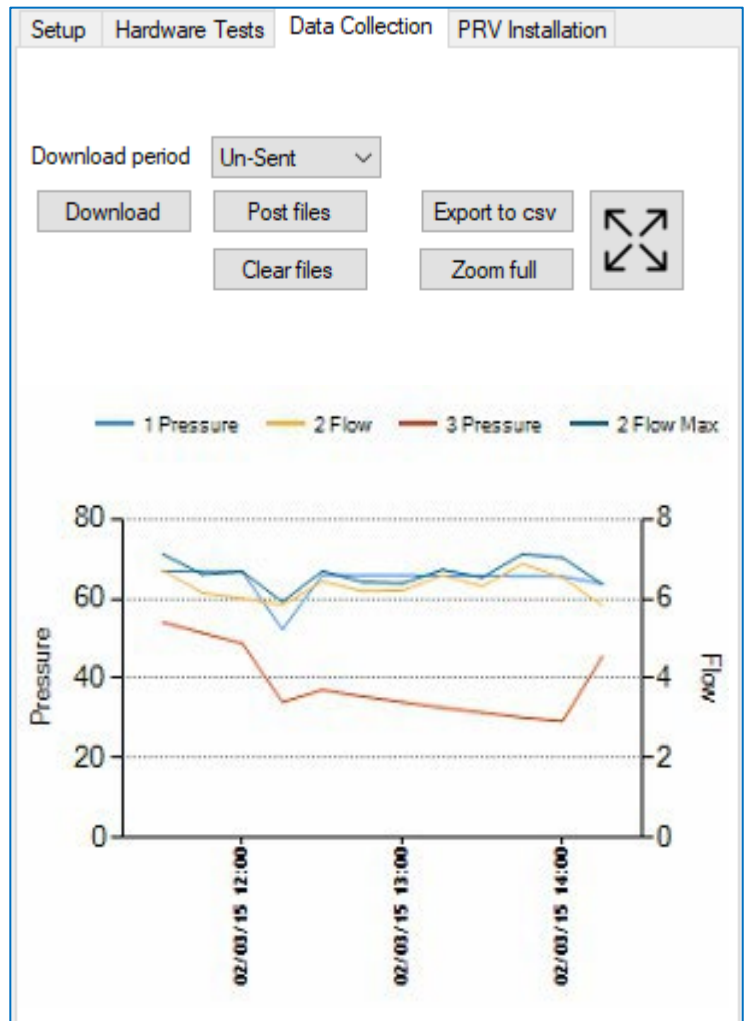

## 6 CONNECTION INFORMATION

### 6.1.1 FLOW Meter connection / cable RAG 93

Flow meter pulse unit cable (RAG R93).

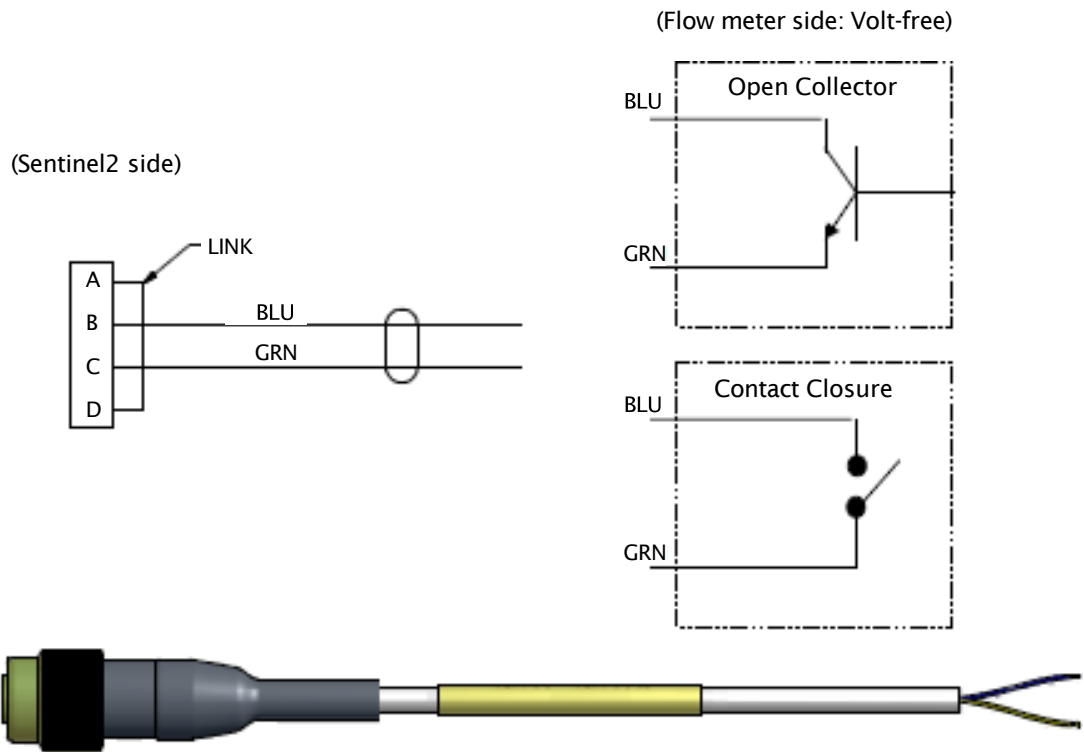

Connect the cable to the flow meter's volt-free pulse interface:

- Use the green wire as ground.
- Use the blue cable as signal.

Direct flow meter connections available on request.

## **7 MAINTENANCE, SERVICE AND REPAIR**

---

Unauthorized servicing will void the warranty and any potential liability for “HWM-Water Ltd”.

### **Electronic controller**

The built-in logger will continue to record data in its memory until the battery completely fails. The data logger cannot be downloaded after this condition occurs.

### **Batteries**

- Only use batteries and parts recommended and provided by HWM.
- Batteries are replaceable by a HWM approved service center or relevantly trained technician.
- Batteries can be returned to HWM for disposal. To arrange the return, complete the on-line RMA form: <https://www.hwmglobal.com/hwm-rma/>  
Refer to the Safety Warnings and Approvals Information for guidelines of the packing requirements.

### **Antenna**

- Only use antenna recommended and provided by HWM.
- For details of antenna options and part-numbers to order, refer to the following link: <https://www.hwmglobal.com/antennas-support/>

### **SIM-card.**

- SIM-cards are replaceable by a HWM approved service center or relevantly trained technician.
- Only use consumable parts recommended and provided by HWM.

### **Hydraulic Components**

- The hydraulic system consists of quick couplings, hoses and actuator that may require maintenance during the normal life of these products. To obtain these parts contact HWM-Water Ltd via your sales representative.

#### **7.1.1 Return of product for Investigation, Service. Or Repair:**

When returning product for investigation or repair, be sure to follow the instructions of your distributor to document why the product is being returned.

If returning to HWM, this can be done by completing the on-line RMA form:

<https://www.hwmglobal.com/hwm-rma/>

Refer to the Safety Warnings and Approvals Information for guidelines of the packing requirements. Prior to shipping, put the equipment into Shipping mode (see section 7.1.2).

## 7.1.2 Putting the equipment into Shipping Mode

Before long term storage, moving an installed unit, or shipping for repair, the Sentinel2 unit should be put into “Shipping mode”. Be sure to upload any unsent data before this operation.

To put the Sentinel2 into shipping mode:

- Read the current configuration of the Sentinel2 using IDT.

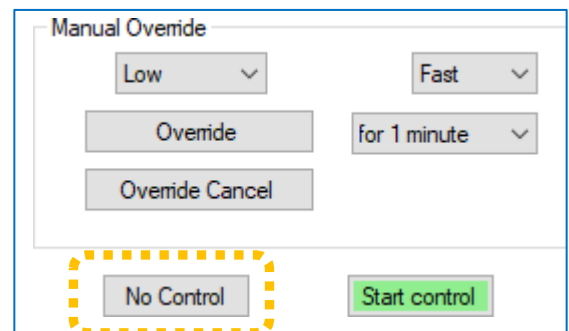

- From within the “PRV Installation” tab, click on the “No Control” button.

Wait until the button has turned pink.

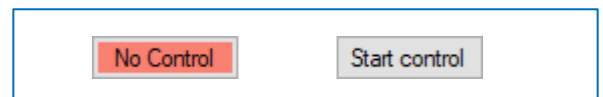

From within the “Setup” tab, scroll to the end of the settings panels and click on the “Stop Device” button.



- Click “Yes” when warned that calls will be stopped.

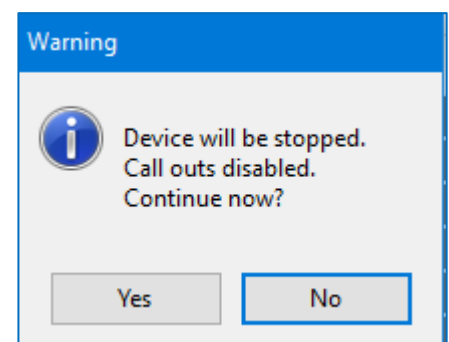

- The unit will be re-programmed. IDT will warn that the logger device has been stopped.
- Click “OK” and confirm that the status of “(Stopped)” is shown at the top of the IDT Logger panel.

Note: The unit may now be re-packed for shipping or long-term storage.

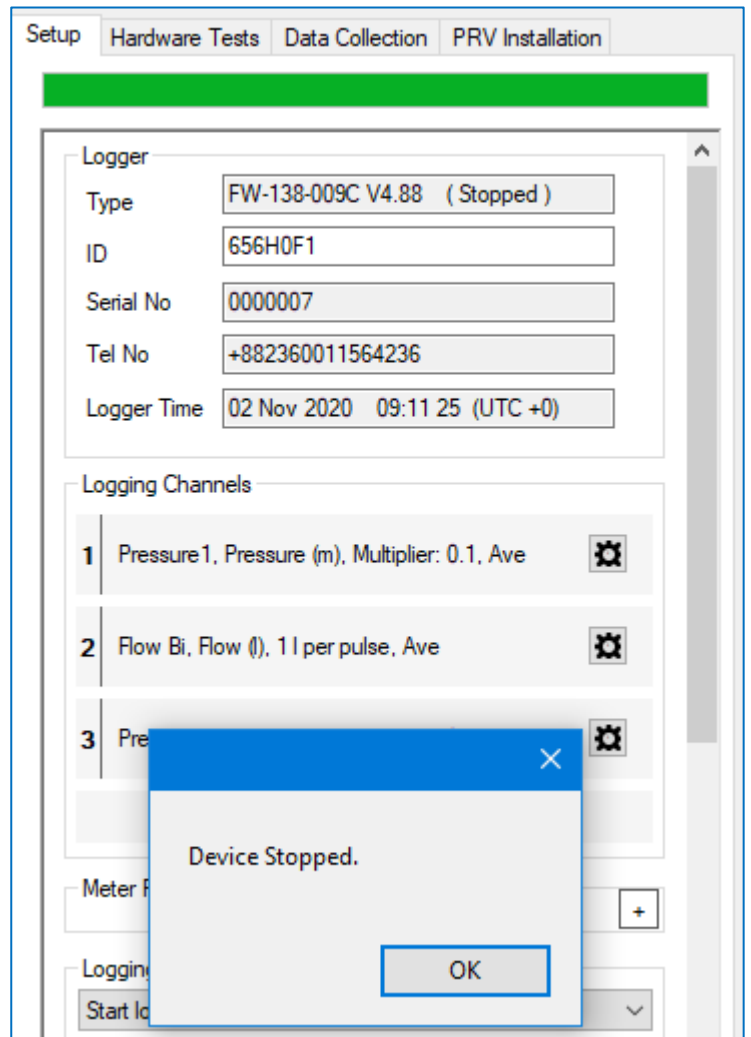

## 8 APPENDIX A – IDT OPTIONS

### 8.1 CHANGE OF UNITS OF MEASURE FOR DISPLAYED DATA

A “Settings” page can be accessed using the IDT menu:

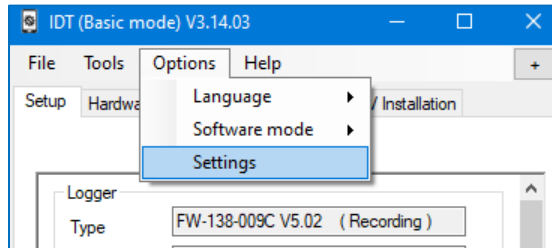

Locate the “Display Units” panel.

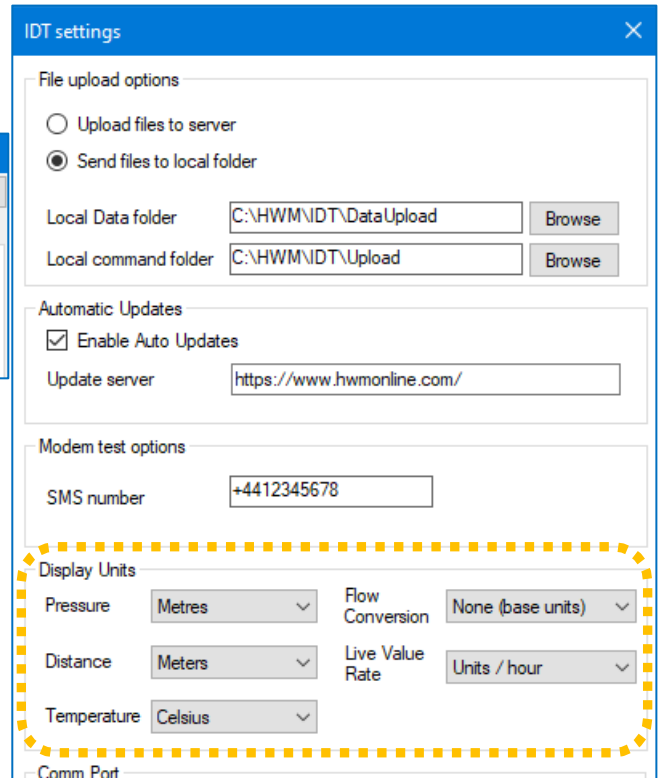

The “Pressure” setting determines how pressure is displayed within IDT.

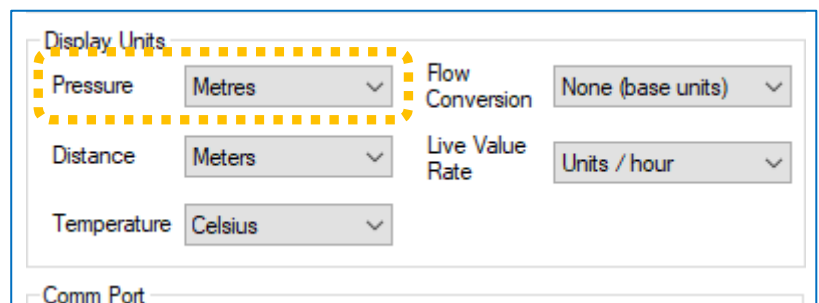

Pick a selection using the drop-down selector.

This is entirely a user preference for using IDT. (Sentinel 2 is unaware of the user’s choice and is not in any way affected. IDT will convert between the display settings and the units Sentinel 2 requires).

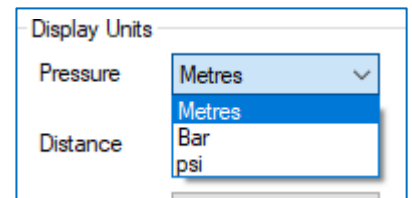



The “Flow Conversion” and “Live Value Rate” settings determine how water Flow is displayed within IDT.

Display Units

Pressure Metres

Distance Meters

Temperature Celsius

Flow Conversion None (base units)

Live Value Rate Units / hour

Comm Port

Pick a Flow Conversion selection using the drop-down selector.

Base units for Sentinel 2 flow measurements are “liters per second”. Other options are listed.

Flow Conversion None (base units)

Live Value Rate m3/hour

Pick a Live Value Rate selection using the drop-down selector.

Live Value Rate Units / hour

Units / second

Units / minute

Units / hour

The Flow selections are entirely a user preference for using IDT. (Sentinel 2 is unaware of the user’s choice and is not in any way affected. IDT will convert between the display settings and the units Sentinel 2 requires).

By making the appropriate selections, the user can modify the way IDT presents control tables.

e.g. The flow conversion can be changed from being displayed in units of liters per second to units of cubic meters per hour. The user can then key in values (in cubic meters per hour) and IDT will convert the values to liters per second during any save of the program to the Sentinel 2 unit.

Flow Control

Low Flow l/s 180.00

High Flow l/s 792.00



Flow Control

Low Flow l/s 0.18

High Flow l/s 0.79



Fluid Conservation Systems  
1960 Old Gatesburg Road Ste #150  
State College, PA 16803  
(800)531-5465  
[fluidconservation.com](http://fluidconservation.com)

©HWM-Water Limited. This document is the property of HWM-Water Ltd. and must not be copied or disclosed to a third party without the permission of the company. All images, text and designs are protected by international and UK copywrite law and remain the property of HWM-Water. It is against the law to copy or use any of the content from the HWM website or literature without the written consent of HWM-Water. HWM-Water Ltd reserve the right to vary the specification.